

Alterations in the behaviour and level of neurotransmitters after acute and repeated administration of the psychostimulant plant, *Catha edulis* and its active principle, cathinone in rats



DISSERTATION

der Fakultät für Biologie
der Eberhard Karls Universität Tübingen
zur Erlangung des Grades eines Doktors der Naturwissenschaften

vorgelegt von

MEHRET YERDAW BANJAW

aus

Shoa, Äthiopien

2005

Alterations in the behaviour and level of neurotransmitters after acute and repeated administration of the psychostimulant plant, *Catha edulis*, and its active principle, cathinone, in rat

DISSERTATION

der Fakultät für Biologie
der Eberhard Karls Universität Tübingen
zur Erlangung des Grades eines Doktors der Naturwissenschaften

vorgelegt von

MEHRET YERDAW BANJAW
aus

Shoa, Äthiopien

2005

Tag der mündlichen Prüfung:

22. 07. 2005

Dekan:

Prof. Dr. Friedrich Schöffl

1. Berichterstatter:

Prof. Dr. Werner J. Schmidt

2. Berichterstatter:

PD Dr. Markus Fendt

ORIGINAL PUBLICATIONS

This dissertation is based on the following articles, which are referred as manuscripts I-V in the text.

- I. Banjaw MY and Schmidt WJ (2004) Lyophilisation and freeze-precipitation as a method for crude extraction of cathinone from *Catha edulis* leaves with minimum thermal injury. *Chemistry of natural compound* 40: 611-612
- II. Banjaw MY and Schmidt WJ (2005) Behavioural sensitisation following repeated intermittent oral administration of *Catha edulis* in rats. *Behav Brain Res*,156: 181-189
- III. Banjaw MY, Fendt M and Schmidt WJ(2005) Clozapine attenuates the locomotor Sensitisation and the prepulse inhibition deficit induced by a repeated oral administration of *Catha edulis* extract and cathinone in rats. *Behav Brain Res*. 160: 365-373
- IV. Banjaw MY, Miczek K and Schmidt WJ (2005) Repeated *Catha edulis* oral administration enhances the baseline aggressive behaviour in isolated rats. In press, *Journal of Neural Transmission*
- V. Banjaw MY, Mayerhofer A and Schmidt WJ (2003) Anticataleptic activity of cathinone and MDMA (Ecstasy) upon acute and subchronic administration in rat. *Synapse* 49: 232-8

CONTENTS

ABBREVIATIONS

ABSTRACT

THE OBJECTIVES OF THE STUDY	1
1. INTRODUCTION	4
1.1 The psychostimulant plant, <i>Catha edulis</i>	5
1.2 Basal ganglia and limbic system	10
1.3 Neurotransmitters	14
1.4 Behavioural sensitisation and psychosis	17
1.5 Prepulse inhibition deficit and schizophrenia	19
1.6 Psychostimulant induced aggression	19
1.7 Treatment of psychopathological disorders	20
1.8 Antiparkinsonian agents	21
2 MATERIALS AND METHODS	22
3. SUMMARY OF RESULTS (MANUSCRIPTS I-V)	30
4. GENERAL DISCUSSION (MANUSCRIPTS I-V)	34
5. CONCLUSIONS AND RECOMMENDATIONS	43
6. REFERENCES	45
APPENDICES OF ORIGINAL PUBLICATIONS	
ACKNOWLEDGMENTS	
CURRICULUM VITAE	

ABBREVIATIONS

ASR:	Acoustic startle response
Amyg:	Amygdala
aCpu:	Anterior caudate-putamen
AT:	Anterior nucleus of thalamus
PnC:	Caudal pontine reticular nucleus
COMT:	Catechol- <i>O</i> -methyltransferase
DB:	Diagonal band of Broca
DOPAC:	3,4-Dihydroxyphenylacetic acid
DA:	Dopamine
GPe:	External globus pallidus
H:	Habenula
HPLC:	High performance liquid chromatography
Hippo:	Hippocampus
HVA:	Homovanillic acid
5-HIAA :	5-Hydroxyindolacetic acid
5-HT:	5-Hydroxytryptamine (Serotonin)
LH:	Lateral hypothalamus
GPi :	Internal globus pallidus
IP:	Interpenduncular nucleus
MFB:	Medial forebrain bundle
mPFC:	Medial pre-frontal cortex
METH:	Methamphetamine
3-MT:	3-methoxytyramine
NMDA:	N-methyl-D-aspartate
NA:	Noradrenaline
Nacc:	Nucleus accumbens
AcbSh:	Nucleus accumbens shell;
AcbC:	Nucleus accumbens core.
B:	Nucleus basalis of Meynert
Tub:	Olfactory tubercle
PPTg:	Pedunculopontine tegmental nucleus
pCpu:	Posterior caudate-putamen (dorsal striatum)
PFC:	Prefrontal cortex
PPI:	Prepulse inhibition
SEM:	Standard error mean
M Str:	Stria medullaris
SNpc:	Substantia nigra pars compacta
SNpr:	substantia nigra pars reticulata
STN:	Subthalamic nucleus
Th or THAL:	Thalamus
VMAT:	Vascular monoamine transporter
VTA:	Ventral tegmental area
VP:	Ventral pallidum

ABSTRACT

It has been generally demonstrated that upon repeated administration, psychostimulants induce behavioural and neuronal alteration in laboratory animals. The alteration induced by one psychostimulant may however differ from another depending upon the mechanism of action, each psychostimulant is manifesting. In general it has been agreed that behavioural sensitisation plays an important role in the development of drug addiction and psychopathological disorders. In this dissertation, the effects of acute and repeated oral administration of *Catha edulis* or its active principle, cathinone on the behaviour and level of neurotransmitters was assessed using Sprague-Dawley rats. The results show that repeated oral administration of *Catha edulis* extracts or the active principle cathinone lead to locomotor sensitisation, bizarre stereotypy behaviours, deficit in prepulse inhibition, and aggression. These altered behaviours in animals are considered to be a strong hint on psychotic phenomena in humans. The locomotor sensitisation and prepulse inhibition deficit induced by repeated administration of *Catha edulis* or cathinone were attenuated by repeated administration of atypical antipsychotic drug, clozapine, i.e., upon a retest the animals behaved as if they had received *Catha edulis* or cathinone for the first time. Similarly, our data show that repeated oral administration of *Catha edulis* extract to isolated rats enhanced the baseline aggression. The neurotransmitters correlates for each study also show the presence of alterations in the level of neurotransmitters in different regions. It is difficult to assign, however, behavioural alteration to a single neurotransmitter because of the complex nature of brain neuronal circuitry and the different effects that these neurotransmitters have at different synapses. Finally, despite *Catha edulis* negative consequences, as demonstrated above, the active component of this plant, cathinone reduced haloperidol-induced catalepsy in animal model. Which could be important for future development of new anti-parkinsonian drugs with limited dyskinesia inducing potential or it could as well be an important treatment armamentarium for Parkinson's disease.

THE OBJECTIVES OF THE STUDY

Catha edulis Forsk (Celastraceae), a plant containing the active principle, S-(-)-cathinone, is often chewed in Ethiopia without any restriction by law enforcement officials. On the contrary, the plant active principle, S-(-)-cathinone is a schedule I of the controlled substance Act (according to the United Nations Drug and Crime control). Cathinone's derivative, cathine is also a schedule IV psychomimetic drug. In the past, *Catha edulis* was grown in Ethiopia on a limited scale in a certain geographical locations and used to be chewed only by a few number of people (especially elderly) either for religious purpose or entertainment reasons. Its use is now gradually becoming an omnipresent phenomenon in the country (Zeina, 1988; Selassie and Gebre, 1996; Kebede, 2002, Dhaifalah and Santavy, 2004). Sometimes, *Catha edulis* may be chewed along with nicotine and alcohol. This scenario makes the problem even more complex (Zeina, 1988; Kebede, 2002). Nowadays, with the exception of children, all categories of people and ages, including college and university students are exposed to such potential psychostimulants (Zeina, 1988; Kebede, 2002). It has become customary to observe truck, bus or taxi drivers chewing *Catha edulis* while executing their daily duties. *Catha edulis* used to be sold in the past in a restricted areas but now is sold freely on the open market in the major cities of Ethiopia or elsewhere without any interventions. Attempts made by the society to reduce its widespread are not significant. On the contrary, the problems associated with *Catha edulis* use are emerging (Giannini and Castellani, 1982; Al-Meshal et al., 1991; Alem and Shibre, 1997; Awas et al., 1999; Ayana et al., 2002).

In the social sphere, family disruption is a prominent problem, which includes frequent quarrels among family members, breach of family ties, neglect of the education and care of children and waste of family resources. The problem is not only limited to social norm disturbances but also encompasses economic problems, such as spread of corruption, the loss of many working hours among civil servants and private employees, the theft of public and

private property to support the habit. Furthermore, it burdens the existing meagre health facilities due to psychiatric disturbance and violence (Alem and Shibre, 1997; Awas et al., 1999; Ayana et al., 2002). It may also lead to property damages by accidents that occur driving under euphoric state. Some survey studies indicated that the prevalence of *Catha edulis* chewing, particularly among the young generation was quite high (Kebede, 2002). There were considerable high life time exposure among the society (Awas et al., 1999; Alem and Shibru, 1997). A stratified random sampling survey and clinical diagnostic studies in Butajira, Southern Ethiopia, indicated the presence of association between *Catha edulis* consumption and the weighted aggregate lifetime prevalence of psychiatric morbidity such as dissociative, mood, somatoform and anxiety disorders (Awas et al., 1999). Diagnostic studies in mental sick individuals admitted to Amanuel Hospital, Addis Ababa, Ethiopia, revealed also the presence of episodic psychosis attributed to heavy *Catha edulis* chewing (Alem and Shibru, 1997). Animal studies also demonstrate the presence of neurological disturbance after administration of cathinone or its relative congener (Gosnell et al., 1996; Sparago et al., 1996).

Although *Catha edulis* use has increased over the past several years, limited studies have been conducted regarding its long-term effects since *Catha edulis* use has been viewed with both curiosity and disdain by the developed nations (Balint et al., 1991). One of the main reason is that S-(-)-cathinone or cathine do not constitutes a major drug abuse problem in the west. This accounts for the relative lack of interest pursuing research in this direction. Therefore, based on the aforementioned facts, it is plausible to pursue further investigations on the impact of long-term *Catha edulis* administration on animal models.

Research Objectives: This project has the following guiding objectives which are meant to focus and shape the study (research) process. The objectives are divided into as general and specific objectives:

General Objectives:

- To investigate alterations in the behaviour upon acute and subchronic exposure to *Catha edulis* extracts or commercial cathinone in the laboratory animals using different paradigms.
- To assess alterations in the level of neurotransmitters upon acute and subchronic *Catha edulis* administration and its active principle, S-(-)-cathinone.
- To correlate such alterations if possible with clinical reported psychopathological disorders and look for treatment strategies.

Specific Objectives:

- To study the behavioural alterations associated with *Catha edulis* or cathinone administration using animal models of different psychosis (locomotor sensitisation, stereotypy behaviour, prepulse inhibition deficit of a startle reflex, aggression and catalepsy test).
- To analyse alterations in the level of brain's neurotransmitters DA, 5-HT and corresponding metabolites) upon acute and subchronic administration of the extracts of *Catha edulis* or commercial, S-(-)-cathinone;
- To compare the potency *Catha edulis* extract with that of commercially available cathinone or amphetamine.
- To study the withdrawal effect of *Catha edulis* or commercial S-(-)-cathinone after subchronic administration and
- To study the effective of S-(-)-cathinone on haloperidol induced catalepsy
- To design or look for treatment strategies for psychopathologies associated with *Catha edulis* chewing.

1. INTRODUCTION

Misuse of psychostimulants is increasing from time to time (Scholey et al., 2004; Shearer and Gowing, 2004; Yamamoto, 2004). Among the main contributing factors for their misuse are the presence of illicit drug-dealing groups, which indiscriminately offer drugs, the current wide distribution network such as the Internet and mobile phones and finally their availability at an affordable price even in small communities and cities. It has become customary nowadays to take the psychostimulants either at a casual gathering or at home for recreational purposes (Simantov, 2004). Generally, the notion behind for such indulgence or misuse is suggested to be for example for feeling at ease from daily stresses, having a sense of well-being and overcoming failure or social defeat. Their frequent uses may lead to a further appetite for more and more, in most case, end up in a repeated misuse or poly-drug uses (Scholey et al., 2004, Yamamoto, 2004). Psychostimulant abuses are often accompanied by psychiatric problems (Farrell et al., 2002; Chen et al., 2003; Srisurapanont et al., 2003; Henquet et al., 2005). This adds a further burden to the already existing disease conditions and level of unmet treatment need. Educational teaching to the general public by way of demonstrating the relation between psychostimulants misuse and psychiatric problem has been strongly suggested as one of the strategies to curve further misuses (Yamamoto, 2004). It would be beyond the scope of this dissertation to discuss the problem of psychostimulants in general. Therefore, this piece of work rather focuses on the impact of a more communal type of psychostimulant, *Catha edulis* and its active principle, cathinone. The plant is widely consumed in Ethiopia and some neighbouring countries thinking that it has both medicinal and psychostimulant effects. However, in the clinical survey, it has been shown that *Catha edulis* chewing may lead to a psychiatric problem upon repeated misuse. To prove this hypothesis, the following questions were addressed in this dissertation: 1) Could *Catha edulis* induce alteration on the behaviour in rats if administered acutely or repeatedly? 2) Could repeated *Catha edulis* / cathinone induce any alteration on the level of neurotransmitter in the

basal ganglia and limbic system in rats? 3) Could atypical antipsychotic drugs affect the expression of behavioural sensitisation in rats? 4) Could *Catha edulis* induce aggression in socially isolated rats upon intermittent administration? and 5) Is there any therapeutic value of the active constituent of this plant?

Finally, the dissertation is presented schematically to address the following topics: The objective of the study was presented as a preamble for the introductory section. In the introductory, under section 1.1, the psychostimulant plant, *Catha edulis* and its effects will be shortly described. In section 1.2, the role of the basal ganglia and limbic system in relation with cortical structure will be described since these structures are for instance important for the patho-psychological processes. In section 1.3, the role of specific neurotransmitters will be shortly outlined. These neurotransmitters play a major role in level-setting processes and sanity of the brain. Section 1.4 outlines the causes of behavioural sensitisation and psychosis and while section 1.5 briefly describe prepulse inhibition deficit and schizophrenia. The remaining of the introductory, 1.6, 1.7 and 1.8, are assigned for psychostimulant induced aggression, Parkinson's disease (PD) and treatment of psychopathological disorders respectively. Section 2 is denoted for the summary of the methods and basic apparatus employed. Section 3 deals on a short summary of the publications. Section 4 is assigned for general discussion. Last but not least, section 5 is allotted for conclusions and recommendations. This latter section is followed by references, acknowledgements, appendices of original publications and curriculum vitae.

1.1 The psychostimulant plant, Catha edulis

Catha edulis Forsk (Celastraceae), popularly known as "Khat" is a large shrub (Fig.1). The leaves of which are used as a stimulant or a medicine in certain regions of East Africa and Arabia. It has been used since antiquity as a religious, recreational, mood, thought and feeling altering drug (Hill, 1965; Brenneisen et al., 1990; Selassie and Gebre, 1996; Al-Motarreb et

al., 2002; BBC news, 2002). *Catha edulis* was probably known and used on the Ethiopian uplands in very ancient times. It seems that it originated there and afterwards spread to the surrounding neighbours, Kenya, Malawi, Uganda, Tanzania, Arabia, the Congo, Zimbabwe, Zambia, and South Africa (UN, 1956; Shadan and Shellard, 1962; Elmi et al., 1987; Dechass, 2001). And even made available to US and Europe, among immigrants from Yemen and the East African nations of Somalia and Ethiopia (Nencini et al., 1989).



Fig.1 *Catha edulis*: Plantation (A) and Bundle prepared for sales (B)

Catha edulis is a natural stimulant from the flowering evergreen tree which grows to tree size interspersed between coffee trees. It reaches heights from 3 to 6 meter. It is a thirsty seedless plant which best grows above sea level (1500m) and can withstand droughts for several months while other crops fail (Dechass, 2001). Fresh *Catha edulis* leaves are crimson-brown and glossy but become yellow-green and leathery as they age. The leaves emit a strong smell because of the enol compound produced from the active constituent. The traditional way to consume *Catha edulis* is to pick a few leaves of a young shoot and to chew them slowly (Fig. 2). The most favoured part of the leaves are the young shoots near the top of the plant. However, leaves and stems at the middle and lower sections are also used. Fresh *Catha edulis* leaves are typically chewed like tobacco.



Fig. 2 Traditional way of chewing *Catha edulis* (picture adapted from BBC news, 2002)

Once the first few leaves are pulped, they are kept in the side of the cheek until the mouth filled with fresh leaves. The user then chews intermittently to release the active components. The old would be chewed for a while and then fresh leaves would be again ingested to keep on filling the mouth. The chewing of *Catha edulis* leaves produces a strong aroma and

generates intense thirst. Thus, to soothe the thirsty mouth, the chewers, in most cases, take fluid intermittently, either in the forms of soft drinks, coffee or tea. The process of chewing is continuous until the person feels a hedonic feeling. In general, the entire chewing process, including the ceremony may take roughly 3-7 hours. Whereas, the extraction of the alkaloid, cathinone and its release into the system may take 15 to 45 minutes. Once the alkaloid enters the system, users claim that they feel a sort of thrill or they talk a lot without feeling sleepy or they remain alert overnight. Additionally, the users believe that they think more clearly and quickly. They claim that they have a sense of well-being, increased energy, over-confidence and improved cognitive ability. Both fatigue and hunger are eliminated. Such false notions associated with chewing of *Catha edulis* lured even some colleges' and universities' communities to depend on *Catha edulis*' leaves (Zein, 1988; Kebede, 2002). The literature on *Catha edulis* Forsk (Celastraceae) is fairly extensive. In the past, studies have been conducted on its botanical description, chemistry and pharmacology. A short summary over its botanical description is already mentioned above. The chemistry of *Catha edulis* has been an intriguing puzzle to both plant chemists and pharmacologists for years (UN, 1975; 1977; Szendrei, 1980). The characteristic stimulant activity of the fresh plant material could not be fully explained in terms of the then known *Catha edulis*' component, cathine. Thus, until not very long ago, the active component present in the fresh leaves of *Catha edulis* was isolated (UN, 1975; Szendrei, 1980) and found to be cathinone (Fig. 3). The leaves contain also cathine, cathidine, celastrin, edulin, choline, ratine, tannin, amino acids, minerals and vitamins especially vitamin C (Szendrei, 1980). Cathine (pseudo-ephedrine) is produced when the ketone (=O) functional group of cathinone (Fig. 3) is reduced to a corresponding alcohol (-OH) group.

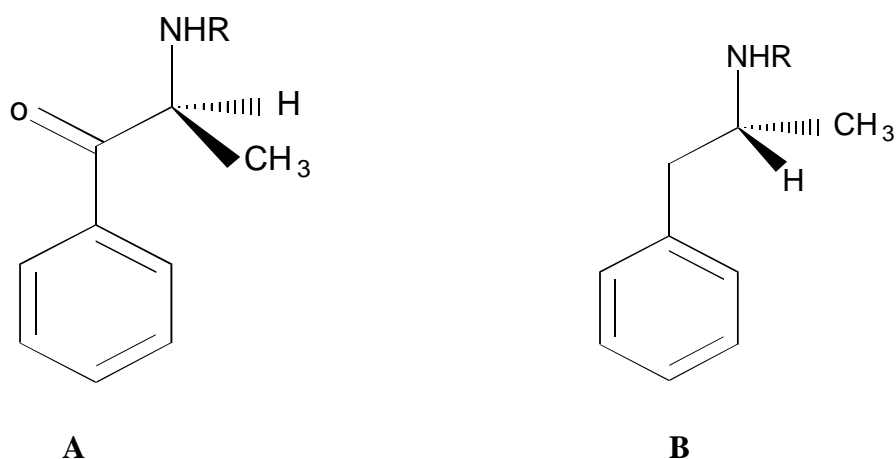

Fig. 3 Structural relationship between the optical isomers of methcathinone, Cathinone, methamphetamine and amphetamine. [A]: R= -CH₃, S-(-)-Methcathinone; R= -H, S-(-)-cathinone. [B]: R= -CH₃, R-(-)-Methamphetamine; R= -H R-(-)-Amphetamine.

Studies on *Catha edulis* illustrated the importance of using freshly harvested young shoots and leaves since the active component, cathinone, readily converts to a reduced product, cathine (alcoholic group) upon drying or storage of the cut plant material (Szendrei, 1980). That is the reason why seller wraps the fresh leaves of *Catha edulis* with banana leaves immediately in order to minimize sunlight induced oxidation (Fig.1 B).

The pharmacology of S-(-)-cathinone and its derivatives in the central and peripheral nervous systems is previously reported (Kalix and Branden, 1985; Kalix, 1991; Widler et al.,1994; Gosnell et al., 1996; Sparago et al., 1996; Fleckenstein et al.,1999; Al-Motarreb et al., 2002). S-(-)-cathinone is regarded as an amphetamine-like sympathomimetic amine (Fig. 3). A wide variety of in vitro and in vivo experiments demonstrate that cathinone shares the action of amphetamine on CNS as well as its sympathomimetic effects. Scientifically, it was shown that cathinone, the active principle of *Catha edulis*, achieves a maximum plasma level after 1-2hr after oral administration and has a half life of approximately 3hr in human (Zelger et al.,1980; Widler et al., 1994; Toennes and Kauert, 2002; Toennes et al., 2003). The effect of cathinone occurs within 15 min under conditions that require 30 min for amphetamine (Cho and Segal,

1994). It was shown that *Catha edulis*, along with its active principle, S-(-)-cathinone enhances locomotion in rats (Zelger, *et al.* 1980; Kalix and Branden, 1985). In the past, enhanced locomotor response induced by S-(-)-cathinone or *Catha edulis*, has been implicated to an increase in the level of dopamine, DA (Kalix, 1982; Kalix, 1991; Mereu *et al.*, 1983; Pehek *et al.*, 1990). Accordingly, *Catha edulis* or its active principle, S-(-)-cathinone, like amphetamine is considered to increase DA availability in the ventral striatum through its action by promoting DA efflux from DA-containing synaptic endings through either reversing the vesicular monoamine transport (VMAT) or the DA uptake transporters (Piffl *et al.*, 1995). S-(-)-cathinone was also implicated to induce alteration in the serotonin (Glennon and Liebowitz, 1982; Nielsen, 1985). Recently, it was documented that S-(-)-cathinone may also act on noradrenaline transporters (Rothman *et al.*, 2003). Therefore, at this juncture, other mechanisms which are not yet elucidated could not be excluded from the pharmacological actions of *Catha edulis* or S-(-)-cathinone. However, support for the hypothesis that amphetamine or cathinone requires an intact dopaminergic system to exert their effects has been demonstrated in the past using dopaminergic antagonists which significantly attenuate stimulant-induced activity (Zelger *et al.*, 1980; Robinson and Becker, 1986; Cho and Segal, 1994). Besides S-(-)-cathinone, cathine (pseudo-ephedrine) or other compounds could as well contribute to the stimulant effect of *Catha edulis* chewing (Szendrei, 1980; Schechter, 1990).

1.2. Basal ganglia and Limbic system

Highly integrated neural functions, such as those involving thought and motor processes, which are generally considered to take place in cortical structures, may be modified by primitive, tonically active, sub-cortical neuronal systems, such as basal ganglia, limbic and reticular activating systems (review, Takakusaki *et al.*, 2004). Accordingly, a dysfunction of these delicately balanced primitive systems may result in derangements of mental processes and lead to psychopathology (Robinson and Becker, 1986; Lipska, 2004).

The basal ganglia are a group of subcortical nuclei involved in multiple segregated parallel loops that modulate cortical activity (refer, Rech and Moore, 1971; Parent et al., 1995; Parent and Hazrati, 1995; Schmidt, 1995; 1998; Schmidt and Kretschmer, 1997). The basal ganglia play a critical but enigmatic role in many aspects of brain function including movements, motivation, reward, and addiction. It is also perceived as important nodes in cortico-subcortical networks involved in the transfer, convergence, and processing of information in motor, cognitive, and limbic domains. The structures involved in this basal ganglia include the caudate (having a tail) nucleus, the putamen (shell shaped) and the globus pallidus (pale body), substantia nigra pars compacta (SNpc), and the subthalamic nucleus (STN) and the motor nuclei of the thalamus. The globus pallidus is further subdivided into the globus pallidus externa (GPe) and globus pallidus interna (GPi). The standard model suggests that there are two pathways through the basal ganglia: direct and indirect (Schmidt, 1995; 1998; Schmidt and Kretschmer, 1997). The direct pathway is thought to facilitate movements while the indirect pathway is thought to suppress movements (Fig. 4). A direct pathway projecting to the thalamus via two GABAergic neurons and an indirect pathway that projects to the thalamus via three GABAergic neurons. Thus, an excitatory cortical input to the striatum is either facilitatory (by the direct pathway) or inhibitory (by the indirect pathway) upon thalamic nuclei which modify movements on a second-to-second basis. The basal ganglia are therefore functionally assisting the cerebellum and the motor cortex. Neurologic disorders such as Parkinson's disease involve the basal ganglia and lead to a slow movement (Schmidt, 1995; 1998; Schmidt and Kretschmer, 1997).

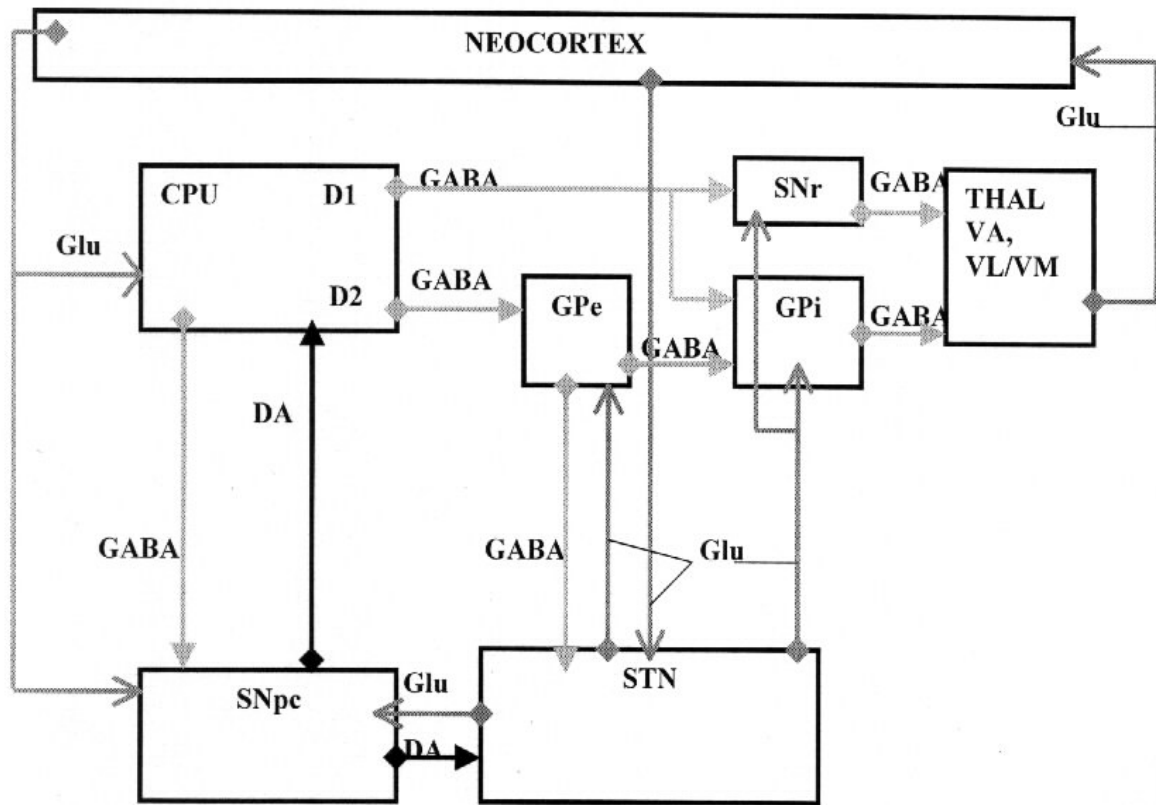

Fig. 4 Schematic presentation of the basal ganglia and its connections (adapted from Schmidt, 1995; 1998; Schmidt and Kretschmer, 1997). Glu: glutamate; DA: Dopamine, GABA: gamma-aminobutyric acid, CPU: Caudate putamen, Gpe: External globus pallidus, Gpi: Internal globus pallidus, SNpc: Substantia nigra pars compacta, STN: Subthalamic Nucleus; THAL: Thalamus, SNr: substantia nigra pars reticulata, D1 & D2: dopamine receptors; VA: Ventral anterior; VL: Ventral lateral, VM: ventral medial.

The limbic system is a group brain structures that are involved in various emotions such as addictions, aggression, fear, pleasure and also in the formation of memory (refer Rech and Moore, 1971; Robinson and Becker, 1986; Kelley et al., 2003; Self, 2004; Kelley, 2004). Its structure lies above and around the thalamus, and just under the cerebrum. And it affects the endocrine and autonomic nervous system as well. The structure includes the nucleus accumbens, the hippocampus, the amygdala, hypothalamus and several other nearby areas. It is tightly connected to the mPFC and VTA (Fig. 5). The limbic system appears to be primarily responsible for our emotional life, and has also a lot to do with the formation of memories. It

is power-packed with functions, all of which are critical for human behaviour and survival. From an evolutionary standpoint, this is an older part of the mammalian brain that enabled animals to experience and express emotions (Rech and Moore, 1971). Thus, the limbic circuit plays a determinant role for understanding psychopathologies like schizophrenia and sensitisation to certain psychostimulants and relapse in drug withdrawal.

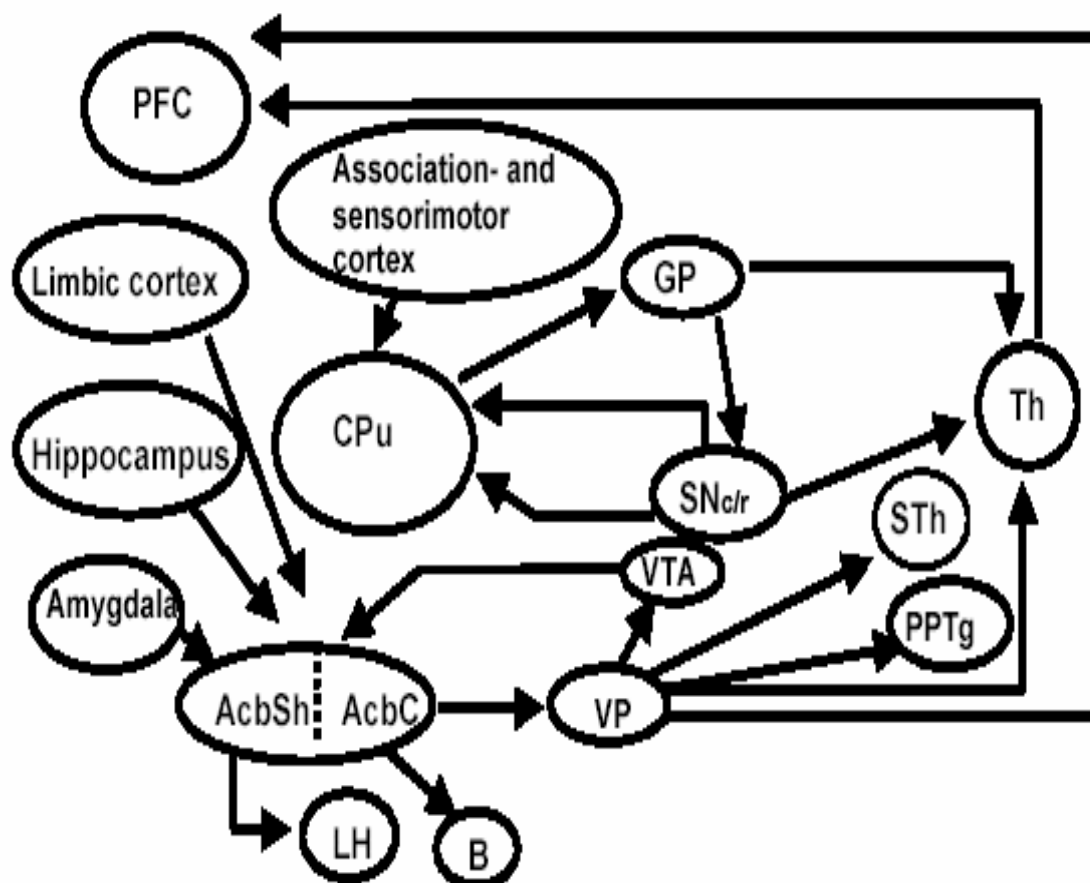

Fig. 5 The basal ganglia and the limbic system connections in the regulation of psychomotor and reinforcement processes (adapted from Honkanen, 1999). **Cpu**: caudate-putamen, **GP**: globus pallidus, **Th**: thalamus, **STh**: subthalamic nucleus, **PPTg**: PedunculopontineTegmental nucleus, **SNc**: substantia nigra pars compacta, **VTA**: ventral tegmental area, **PCF**: prefrontal cortex, **VP**: ventral pallidum, **B**: nucleus basalis of Meynert, **LH**: lateral hypothalamus, **AcbSh**: nucleus accumbens shell; **AcbC**: nucleus accumbens core.

1.3 Neurotransmitters

By means of behavioural or pharmacological (Robinson and Becker, 1986; Schmidt and Kretscher, 1997), electrical or chemical lesion (Agid et al., 1974; Goldstein et al., 1976), electrical stimulation (Voigtlander and Moore, 1971), blocking (Van Zwieten-Boot and Noach, 1975); immunohistological (Hokfelt et al., 1975) and knockout (Caine et al., 2002) studies, it has been shown that neurotransmitters such as catecholamines, amino acids and peptide derivatives are involved in the basal ganglia and limbic systems. It is generally known that many, even possibly all, neurons contain more than one transmitter. Here in this dissertation, only the biogenic amines, particularly *dopamine*, *serotonin* and their corresponding metabolites are dealt due to their relevance to the studies conducted.

Dopamine (DA), or β -(3,4-dihydroxyphenyl)ethylamine is an endogenous catecholamine.

It was first recognized as a neurotransmitter in the central nervous system in 1957 (Carlsson, 1959) and plays a vital role in transmitting signals between neurons, which are separated by a synaptic cleft (Snyder et al., 1970; Cooper et al., 1996; Heidbreder et al., 1996; Schmidt, 1995; 1998; Schmidt and Kretscher, 1997; for a review see Kandel et al., 2000; Dani and Zhou, 2004). DA is widely distributed in the basal and limbic systems. Accordingly, the midbrain DA is the principal neurotransmitter in the following major neural systems in the midbrain: 1) the *nigrostriatal pathway* which originates from DA-synthesising neurons of the midbrain substantia nigra pars compacta (SNc, A9) and innervates the dorsal striatum. The degeneration this DA synthesising neuron leads to Parkinson's disease); 2) the *mesolimbic system* which arises in the midbrain ventral tegmental area (VTA, A10) and innervates the ventral striatum (nucleus accumbens and olfactory tubercle) and part of the limbic system: This system influences motivated behaviour, including activity related to reward; 3) the ventral tegmental area also gives rise to the smaller *mesocortical pathway*, which innervates part of the frontal cortex and may be involved in certain aspects of learning and memory and finally *tubero-infundibular* pathway which supplies DA to the hypothalamus region. The

innervations of widespread area of the brain by this particular neurotransmitter are consistent with the multitude of functions it modulates. And the variety of neuropathological disorders associated to its imbalance (Mansbach et al., 1988; Schmidt, 1995; 1998; Schmidt and Kretschmer, 1997; Siegel et al., 1999; Koch and Fendt, 2003; Miczek et al., 2002; Miczek and Fish, 2005). Medications used to modify behavioural disturbances may be chosen based upon the receptors on which this neurotransmitter exerts its major effect. There are at least 5 DA receptors denoted by subscripts D₁-D₅ (for a review see Kandel et al., 2000; Oak et al., 2000; Dziedzicka-Wasylewska, 2004). The D₁ and D₅ receptors (referred as the D₁ family of receptors) act on G-protein coupled receptors which activate adenylate cyclase, increase cyclic AMP, and are excitatory. The D₂, D₃, and D₄ receptors (the D₂ family act on G-protein coupled receptors which inhibit adenylate cyclase, decrease C-AMP, and are inhibitory). This latter family of receptors are more concentrated in the meso-limbic and meso-cortical pathways and are associated with psychosis and its treatment (Kapur and Seeman, 2001). DA, like other catecholamine neurotransmitters, is synthesized from the amino acid precursor, tyrosine, which has to be taken up through the blood brain barrier by transporters into the dopaminergic cells. The first step in the synthesis of catecholamines is the hydroxylation of tyrosine to dihydroxy phenylalanine (DOPA), by tyrosine hydroxylase, which is also the rate limiting enzyme in the synthetic cascade. In the cytoplasm of cells, DOPA decarboxylase transforms DOPA to DA, which is then carried by another active transporters to synaptic vesicles, where the molecules are protected from catabolizing enzymes. Dopamine is degraded by a two-step process involving the enzymes monoamineoxidase (MAO) and catechol-O-methyltransferase (COMT) (Fig. 6). COMT is primarily active in the synapses whereas, MAO is primarily active in the pre-synaptic terminal against catecholamines that are not safely enclosed in storage vesicles. MAO accounts for a much larger portion of catecholamine metabolism.

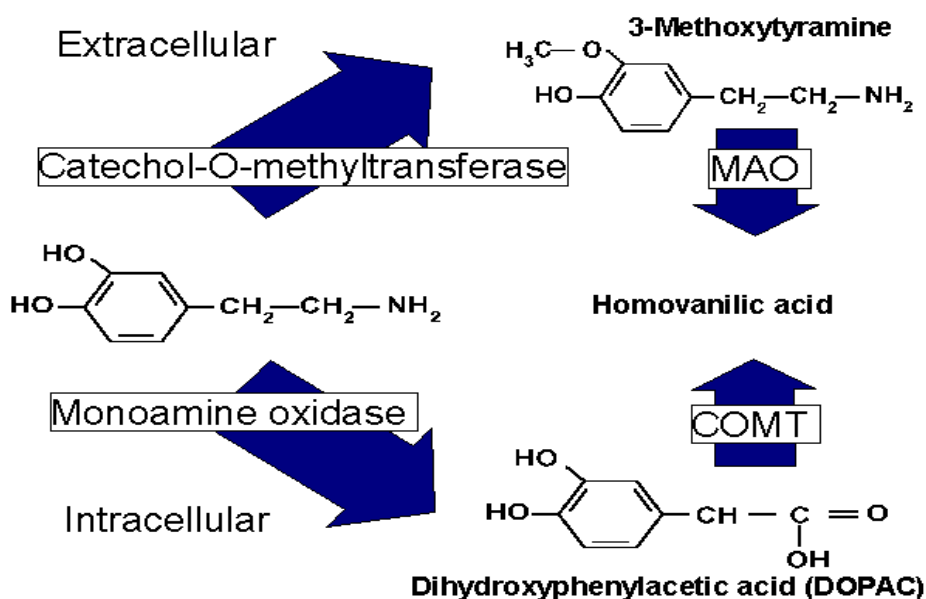

Fig. 6 A simple schematic presentation of dopamine metabolism.

Both movement and psychotic disorders in humans have been associated with disturbances in the functioning of the dopaminergic system.

Serotonin(5-HT) is another important neurotransmitter in the central nervous system. It is an indolamine monoamine. Serotonin neuron project throughout the basal ganglia and limbic systems (for a review see Kandel et al., 2000; Baumgarten and Grozdanovic, 1995). The synthetic pathway for 5-HT is analogous to the catecholamines in many ways. An important distinction however is that the rate limiting step is the uptake of tryptophan into the neuron. Tryptophan is converted to 5-hydroxytryptophan by tryptophan hydroxylase and then this product further gives rise to 5-HT with the help of L-aromatic acid decarboxylase (Birdsall, 1998). The metabolism of serotonin is primarily done by MAO. The principle metabolite is 5HIAA. 5-HT and its receptors are found both in the central and peripheral, especially in the gastro-enteric, nervous system, as well as in a number of non-neuronal tissues. 5-HT produces its effects through a variety of membrane-bound receptors: 5HT₁, 5HT₂, 5HT₃, 5HT₄, 5HT₅, 5HT₆, and 5HT₇ (Cowen, 1991; Hoyer et al., 1994; Saxena, 1995; Barnes and

Sharp, 1999; for a review see a book by Kandel et al., 2000; Meltzer et al., 2003). Within the 5HT₁ group there are subtypes 5HT_{1A}, 5HT_{1B}, 5HT_{1D}, 5HT_{1E}, and 5HT_{1F}. There are three 5HT₂ subtypes, 5HT_{2A}, 5HT_{2B}, and 5HT_{2C} as well as two 5HT₅ subtypes, 5HT_{5a} and 5HT_{5B}. Most of these receptors are coupled to G-proteins that affect the activities of either adenylyate cyclase or phospholipase C. The 5HT₃ class of receptors are ion channels. The serotonergic system is known to modulate mood, emotion, sleep and appetite and thus is implicated in the control of numerous behavioural and physiological functions and has also been implicated in the aetiology of numerous disease states including depression, anxiety, social phobia, schizophrenia, obsessive-compulsive and panic disorders, aggression (Schreiber and De Vry , 1993; Andrews and File, 1993; Eison and Eison, 1994; Deakin,1998). Thus, the development of specific agonists and antagonists to these different types of receptors would be useful in the treatment of various disorders.

1.4 Behavioural sensitisation and psychosis

Repeated treatment with psychostimulant drugs produces alterations in the behaviour that outlast the initial neuropharmacological actions. This is usually illustrated by an increase in the magnitude of the locomotor-stimulatory effects. The phenomenon is often called behavioural sensitisation (Robinson and Becker, 1986; Stewart and Badiani, 1993; Pierce and Kalivas,1997; Kalivas et al.,1993; Segal and Kuczenski,1994; Heidbreder et al.,1996). The progressive augmentation of behavioural responses to psychomotor stimulants persists even after a long period of withdrawal. Particularly, behaviour sensitisation to the psychostimulants develops rapidly even with relatively small doses when the drugs are administered repeatedly in the same distinct environment (Robinson and Becker,1986; Stewart and Badiani , 1993). Thus, the most robust behavioural sensitisation is seen when the experimental animals are removed from their home cage to a distinct experimental arena and the psychostimulants are administered. This form of behavioural sensitisation is often

termed context dependent sensitisation (Robinson and Becker,1986; Stewart and Badiani, 1993; Amtage and Schmidt, 2003). Investigation into the neural basis of behavioural sensitisation has focused on mesoaccumbens projection because of the mature literature implicating this DA pathways in the acute motor and reinforcing effects of amphetamine-like stimulants. Over the last decade, with a few exceptions, the study to correlate behavioural sensitisation with the neuronal-sensitisation has often emerged with inconsistencies (Robinson and Becker, 1986). In contrast, the presence of behavioural sensitisation is consistent event. Generally, it is assumed that the mesoaccumbens' DA projection embedded in the limbic circuit may undergo alteration and produces behavioural sensitisation. The specific changes in the limbic circuit that promote behavioural sensitisation are however under the control of experimental parameters, such as the drug employed, dosage regimen, withdrawal period and the presence of conditioning cues (Robinson and Becker, 1986). Therefore, the profile of a particular neurotransmitter alteration observed after exposure to repeated psychostimulants may vary depending upon the experimental protocol and strain of animals, even though all laboratories report the presence of behavioural sensitisation (Robinson and Becker, 1986). The nature of persistent drug-induced neuro-behavioural adaptations is of interest because they are thought to contribute to the development of drug dependence and addiction and also psychopathologies, e.g. amphetamine psychosis (Robinson and Becker,1986). Accordingly, the primary animal model for psychostimulant-induced psychopathologies involves repeated administration of drug to rodents, which can produce a progressive and enduring augmentation in motor activity (Robinson and Becker,1986; Stewart and Badiani, 1993; Pierce and Kalivas, 1997; Kalivas et al.,1993; Segal and Kuczenski, 1997).

1.5 Prepulse inhibition deficit and Schizophrenia

Schizophrenia has long been associated with abnormalities in the information processing and

attention mechanisms (Grillon et al., 1992; Feldon and Weiner, 1992; Braff, 1993; Swerdlow and Geyer, 1998). In an attempt to better understand the mechanisms underlying pathophysiology of schizophrenia, the sensorimotor gating processes has received much attention. One well-established method for evaluating sensory filtering is the paradigm of prepulse inhibition (PPI) which refers to the inhibition of a startle reflex by presentation of a weak intensity prepulse immediately before the startle stimulus (Koch, 1999; Fendt et al., 2001; Koch and Fendt, 2003). Disruption of PPI in schizophrenic patients has been well described in several studies (Kumari et al., 1999; Geyer et al., 2001; Braff et al., 2001). PPI deficits can also be observed in rats treated with psychotomimetic agents (Andersen and Pouzet, 2001; Bell et al., 2003). The reduction in startle produced by a prepulse stimulus in animal model is equated in many ways with that of a loss of sensorimotor gating in schizophrenic patients which may lead to sensory flooding and cognitive fragmentation. The validity of PPI is demonstrated using several paradigms (for reviews see, Swerdlow et al., 1994; Swerdlow and Geyer, 1998). For example, PPI was disrupted in rats when dopamine was infused or the dopamine agonist apomorphine was administered into the nucleus accumbens which mimicks PPI deficits in schizophrenics. PPI deficits are blocked by antipsychotics, such as haloperidol and clozapine (Swerdlow and Geyer, 1993). Thus, the loss of PPI in dopamine-activated rats may be a valid animal model of sensorimotor gating deficits in schizophrenic patients. This model may help to understand the neurobiology of cognitive deficits in schizophrenic patients

1.6 Psychostimulant induced aggression

The term “aggression” refers to behaviour that is intended to harm another individual (Miczek and Fish, 2005). Animal model of aggression involves manipulation of the brain either pharmacologically or electric stimulation (Siegel et al., 1999; Miczek and Fish, 2005). Psychostimulants are also implicated in aggressive behaviours (Miczek and O'Donnell, 1978;

Sokolov et al., 2004; Curran et al., 2004). There are several forms of aggression, each with specific environmental triggers and serving different functions (Miczek and Fish, 2005). Accordingly, aggression has been delineated into different types, such as offensive and defensive behaviour (Miczek and Fish, 2005). Animal studies of aggression usually involve different paradigms. Among these, isolation-induced aggression is often employed (Matsumoto et al., 1991; Miachon et al., 1993; Leng et al., 2004). In isolation-induced aggression, male mice or rats are isolated for two to six weeks and then placed together for fighting. The latency, duration and intensity of the fighting are measured and later the effects of pharmacological intervention could be assessed. Different neurotransmitters and brain regions are implicated mediating aggression (refer, Miczek and Fish, 2005). Among the neurotransmitters, most emphasis has been drawn to serotonin since it plays a vital role in the modulation of different forms of aggression in rodents (Rilke et al., 1998; Miczek et al., 2002; Miczek and Fish, 2005). Generally 5-HT is the most powerful inhibitor of aggressive behaviour and a loss of 5-HT enhances aggressivity. However, the complexity of the neural circuits and the presence of different neurotransmitters in the brain make the association of a single neurotransmitter to the actual observed aggression complex.

1.7 Treatment of psychopathological disorders

It is generally postulated that psychostimulants act via a circuit involving the ventral tegmental area (VTA), nucleus accumbens (Nacc) and medial prefrontal cortex (mPFC). The PFC sends glutamatergic projections that activate dopaminergic neurons in the VTA. These projections provide an extremely important excitatory drive necessary for the development of behavioural sensitisation. Treatment strategies for psychopathological disorders, therefore, should be based either to attenuate the dopaminergic or glutamatergic overflow. In the last few decades, several antipsychotic drugs, mainly typical and atypical antipsychotic drugs, have apparently been employed in the treatment of psychosis and schizophrenia (Kapur et

al.,1999; Ananth et al., 2001; Remington, 2003). Each antipsychotic drug has its own merits and demerits. Clozapine is considered to be atypical antipsychotic drug and is employed for the treatment of schizophrenia (Kumari et al., 1999). However, the efficacy of each drugs in a particular population is still debatable.

1.8 Antiparkinsonian agents

Unfortunately, there is currently no cure for Parkinson's disease (DA) nor a preventive treatment. Treatment is restricted mainly to symptomatic relief although some agents may offer neuroprotective benefits. The clinical treatment of PD is centred on DA replacement therapy. Levodopa has been the pharmacological standard of care for treating patients with PD in the past. However, its long-term use leads to motor complications, response fluctuations, and dyskinesia (Hurtig, 1997). DA agonists, such as apomorphine are also consider to have beneficiary in the treatment of PD. In addition, some compounds from the 'Ecstasy'-derivatives exert potent anti-parkinsonian activity. For example, 3,4-Methylenedioxymethamphetamine, 'Ecstasy' dose-dependently and very potently reverse haloperidol-induced parkinsonism in the rat (Schmidt et al., 2002, Lebsanft et al., 2005). The search for new therapeutic agent which alleviate the problem associated with PD is still going on. Here, in this thesis, we studied the use of the active constituent of *Catha edulis*, *cathinone* as a potential for the treatment of PD. PD is a gradual progressive neurodegenerative disorder that affects predominantly body movement but also cognition. It is characterized by symptoms such as muscle rigidity, resting tremors, loss of facial expression, hypophonia, diminished blinking, and akinesia (Schmidt, 1995; 1998; Schmidt and Kretschmer, 1997; Betarbet et al., 2002). The motor disabilities characterizing PD are primarily due to the loss of dopaminergic neurons in the substantia nigra resulting in a dramatic decrease in the DA levels in the brain. Once the DA neuronal cell death reaches the critical level, the neurological symptoms of PD appear (Damier et al.,1999; Alam and Schmidt, 2000; Betarbet et al., 2002).

2. MATERIALS AND METHODS

The studies performed in this dissertation are outlined in detail in each of the manuscripts: Manuscript-I outlines the procedures for extraction of crude extract from fresh *Catha edulis* plant. Manuscript-II elucidates the methods for behavioural sensitisation and brain monoamines analyses. Manuscript-III illustrates the procedures for behavioural sensitisation, prepulse inhibition deficit of a startle reflex, attenuation of behavioural sensitisation and prepulse inhibition deficit with the atypical antipsychotic agent, clozapine. The same manuscript also includes procedures for monoamine analyses. Manuscript-IV demonstrates the procedures for aggression test and monoamine analyses. Finally, manuscript-V elucidates the catalepsy and open-field experimental procedures. Thus, it would be rather redundant to repeat once again the same materials and methods in this academic dissertation. Here, a summary of the methods and relevant information, which were not incorporated in the original research reports because of space limitation, are presented here. All the experiments were carried out in the Department of Neuropharmacology, Institute of Zoology, Faculty of Biology, Eberhard Karls University of Tuebingen.

Animals:

Animals employed in all procedures were male Sprague-Dawley rats from Charles River, Sulzfeld, Germany. Prior to any experimental procedures, rats were either group-housed or isolated randomly (depending upon the experimental protocols). They were kept under constant conditions: 12/12 h light /dark cycle (light on 0800 hours), temp (20.9 °C) and humidity (54 –60%) in our laboratory facility. In all cases, rats were fed with 12 g of standard rat chow (Ssniff Spezialdiäten, SOEST, GmbH, Germany) per day and given water ad libitum. Their weights were monitored every day. In all procedures, the rats were left under specified conditions to acclimatize for at least three to five weeks before conducting any experimental procedures. Rats were properly handled by the experimenter and made familiar to gavage administration during the specified periods. All experiments employed in the

manuscripts (II-V) were done in accordance with the European Communities Council Directive of 24 November 1986 (86/609/EEC) and were approved by the local council of animal care (Regierungspräsidium, Tuebingen , ZP 6/03).

Drugs:

Drugs and chemicals employed in this dissertation were scientifically proven quality and from known sources. Purchase of psychostimulant and transportation of *Catha edulis* leaves from Ethiopia to Germany were permitted by “Bundesopiumstelle”

Preparation of the crude extract from *Catha edulis* leaves

The fresh plant, *Catha edulis* was brought from Ethiopia and extracted using a simple freeze-precipitation and lyophilization technique (manuscript I) under minimum thermal injury. Thin layer chromatography (Szendrei, 1980) [Fig. 7], spectrophotometre (Al-Obaid, et al. 1998) [Fig. 8] and high performance liquid chromatography diod array detection (Mathys and Brenneisen,1992; Toennes and Kauert, 2002) [Fig. 9] were employed to identify and also quantify the cathinone in the crude extracts. Commercial cathinone was employed as a standard.

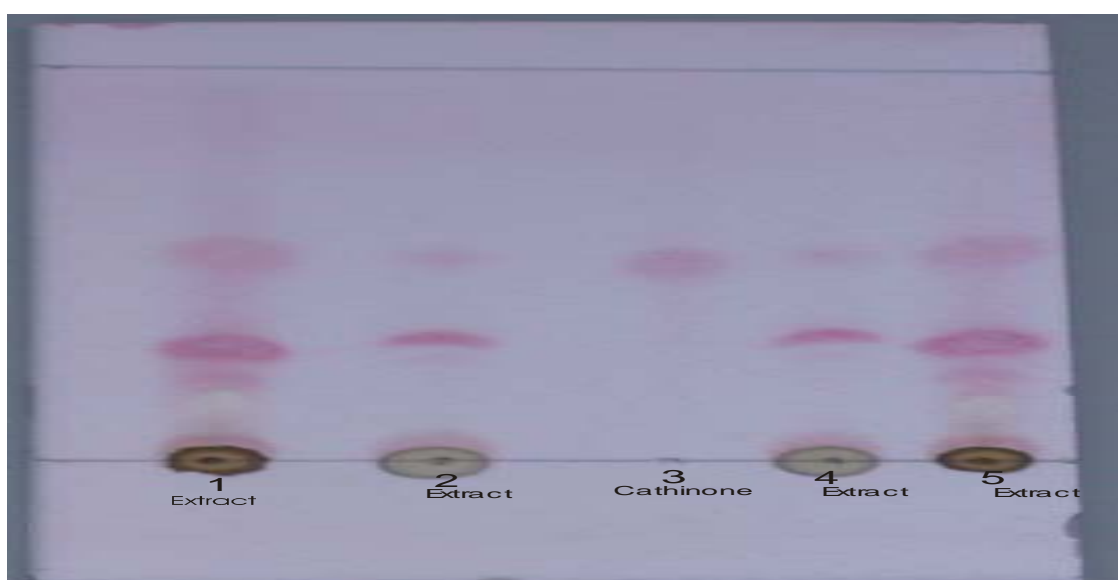

Fig.7 Thin layer chromatography of lyophilised pure cathinone (spot 3) and different concentration of *Catha edulis* extract (spots,1,2,4 and5)

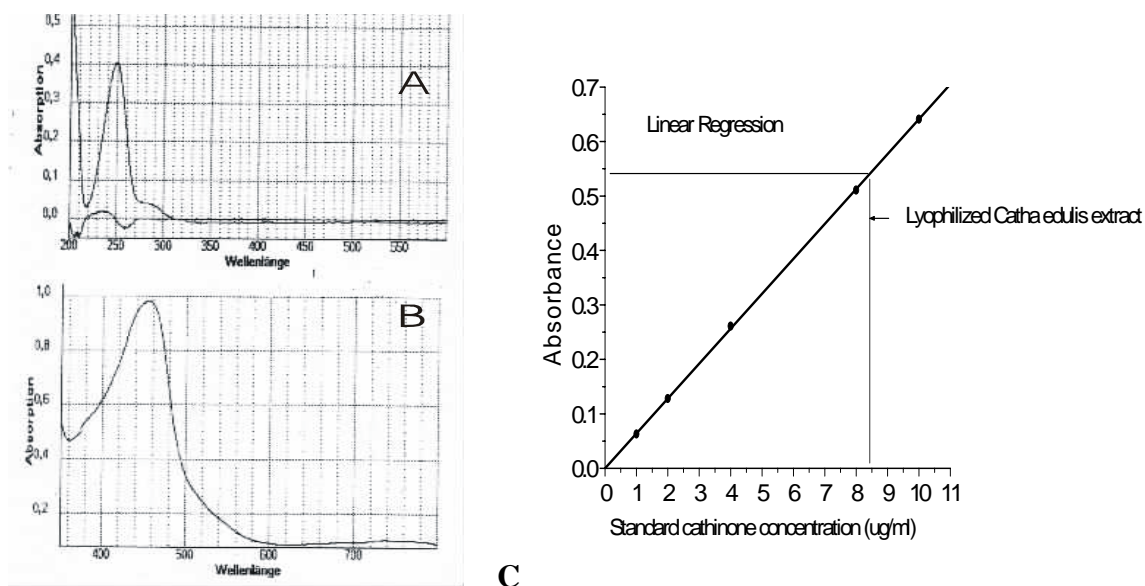

Fig. 8 Spectrophotometric identification and quantification of cathinone in the lyophilized *Catha edulis* extract. A: The chromatogram of pure cathinone HCl at 254 nm. B: The spectrum of cathinone-copper (II)-neocuproine reagent (at 455 nm). C: Linear regression

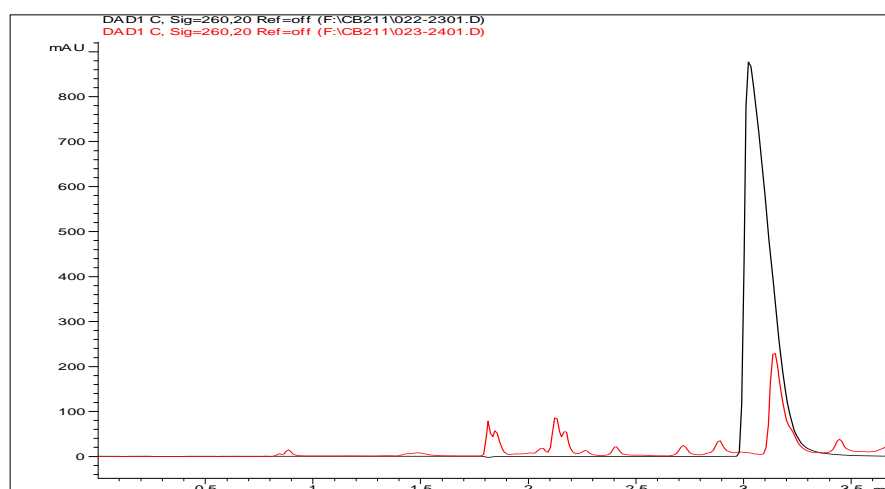

Fig. 9 Representative of HPLC-UV/DAD-chromatogram of pure cathinone (top high single peak) and lyophilized *Catha edulis* extract.

Treatments

In order to administer the lyophilised *Catha edulis* extract, the active principle, cathinone and amphetamine, oral-gavage was employed except in the catalepsy procedure (Fig.10). Such route was used since pharmacokinetics studies showed that *Catha edulis* or S-(-)-cathinone is readily absorbed into plasma from the stomach and mouth (Widler et al., 1994; Toennes et al., 2003). Besides, the *Catha edulis* leaves are usually taken orally in humans. In the catalepsy and openfield experiment, a non-stressed subcutaneous injections was employed (manuscript V).

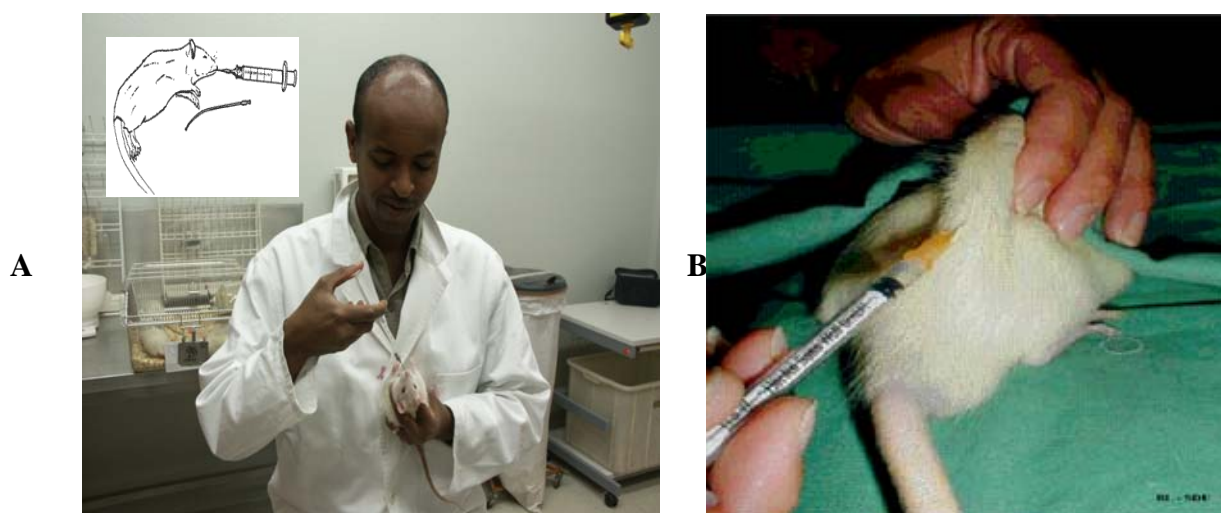

Fig.10 Schematic illustration of the oral-gavage administration (A) and non stressed s.c. injection (B)

Measurement of motor activity

Horizontal and vertical locomotion of rats were assessed using an open-field box (video mounted at the top (Fig. 11A) and activity boxes (Fig. 11B). In the open field hole boards, the behaviour was first videotaped and later offline monitored using a dose-based program. In the activity box, locomotion was monitored using a fully automated computer controlled photocells (Process control motility test 302000, TSE, Technical and Scientific Equipment). Interruptions of horizontal and vertical light beams due to rat's movement were registered

automatically. These data were then later converted to digital values, expressed as distance travelled in meter or number of rearing.

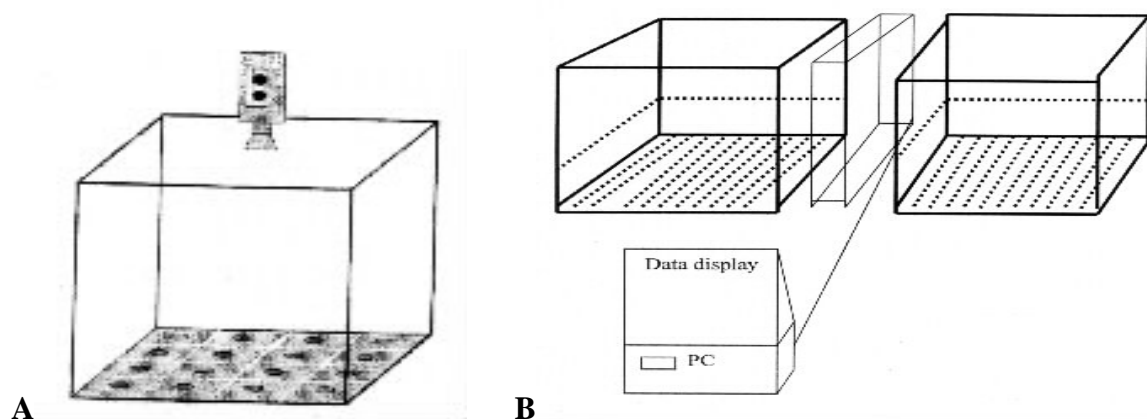

Fig.11 Schematic presentation of open-field box (A) and activity box (B). The black circles on the floor in the Fig. A indicate the open holes for explorations. The dotted lines in the Fig. B display a horizontal and vertical beam lights. Light breaks are registered in the central board and send to the PC for data generations.

Acoustic startle and prepulse inhibitions deficit (PPI)

For PPI measurement, each rat was placed in a wire-mesh test cage which was mounted on a piezoelectric accelerometer (Fig 12). Then the cages were placed in the sound attenuated and well ventilated rectangular boxes. The acoustic startle and prepulse inhibitions were recorded and digitised in the attached computer (manuscript III).



Fig.12 Schematic illustration of the acoustic startle and PPI deficit measurements.

Aggression test

Aggression test was conducted using isolated rats. The rats were kept in small cages isolated for five weeks. Then aggression tests were conducted in a separate room but within their own residence cage except that the wire-top was replaced by a transparent polypropylene cage similar in size with the residence cage (Fig.13A). The behaviour of the rat without or with the presence of intruder was videotaped in hidden arena (Fig. 13 B &C). The video was offline monitored to assess the degree of aggression.

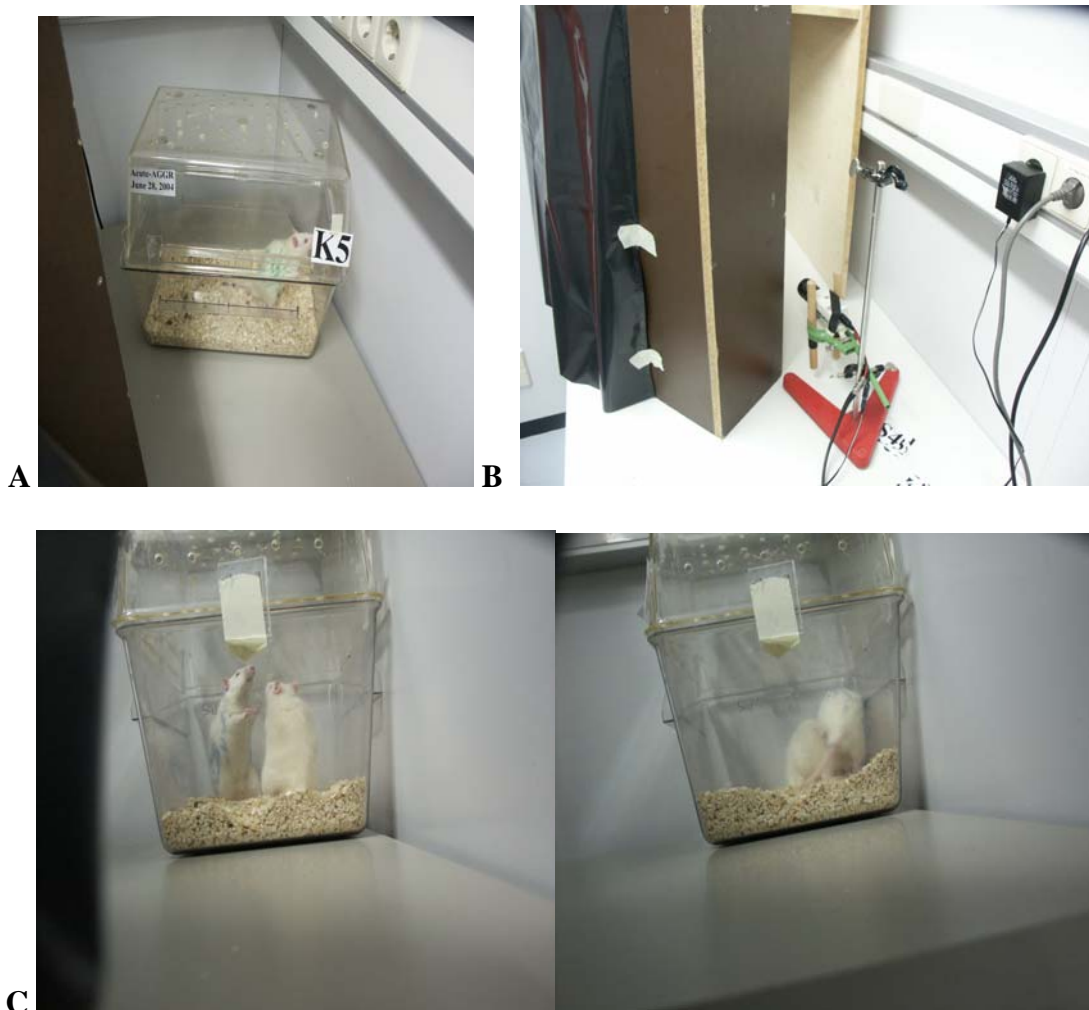

Fig.13 Schematic presentation of isolation induced aggressive paradigm. Patched fur colours show the isolated rat.

Catalepsy test

The animal equivalent of Parkinson's disease "catalepsy" was measured in two established tests: 1) bar: placing both forepaws on a horizontal bar 9cm above floor. 2) grid: hanging the animal with all four paws onto, a vertical grid with grid constant of 0.85 cm. The degree of catalepsy was assessed quantitatively by measuring the time from placement of the animal until removal of one of its paws (descent latency) with cut-off time of 180 s (for details refer manuscript V).

Level of neurotransmitter analyses using EDC-HPLC system

For neurotransmitters analyses, rats were killed by decapitation. Then, each of the brain was removed rapidly and dissected into the various regions according to Heffner et al., 1980 (Fig. 14). The dissected regions were weighed and stored immediately in liquid nitrogen and then later transferred to -80°C until HPLC analyses (for detail procedure refer manuscripts II-IV).

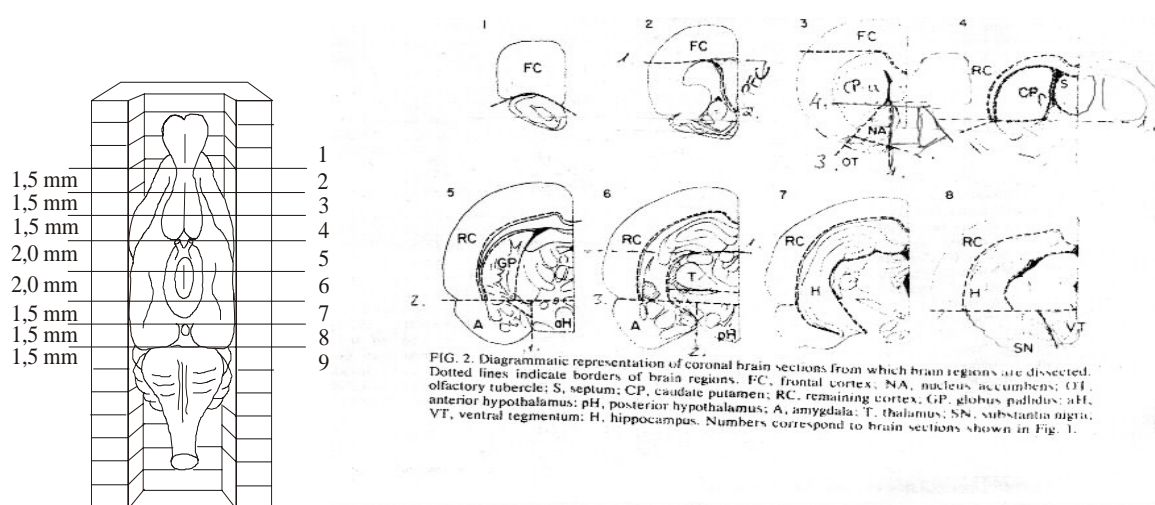

Fig.14 Pictorial presentation of brain dissection (adapted from Heffner et al., 1980)

Measurement of dopamine, serotonin and their metabolites from brain samples.

On the day of the assay, frozen tissue samples were removed from -80°C and immediately homogenized in a specified eluent. The concentration of each neurotransmitter and its corresponding metabolites were analysed by high-performance liquid chromatography with

electrochemical detection. Each tissue sample, after preparation, was auto-injected into a reverse phase column. Quantitative estimation and comparisons were made using internal and external standard chromatograms(Fig.15 A & B).

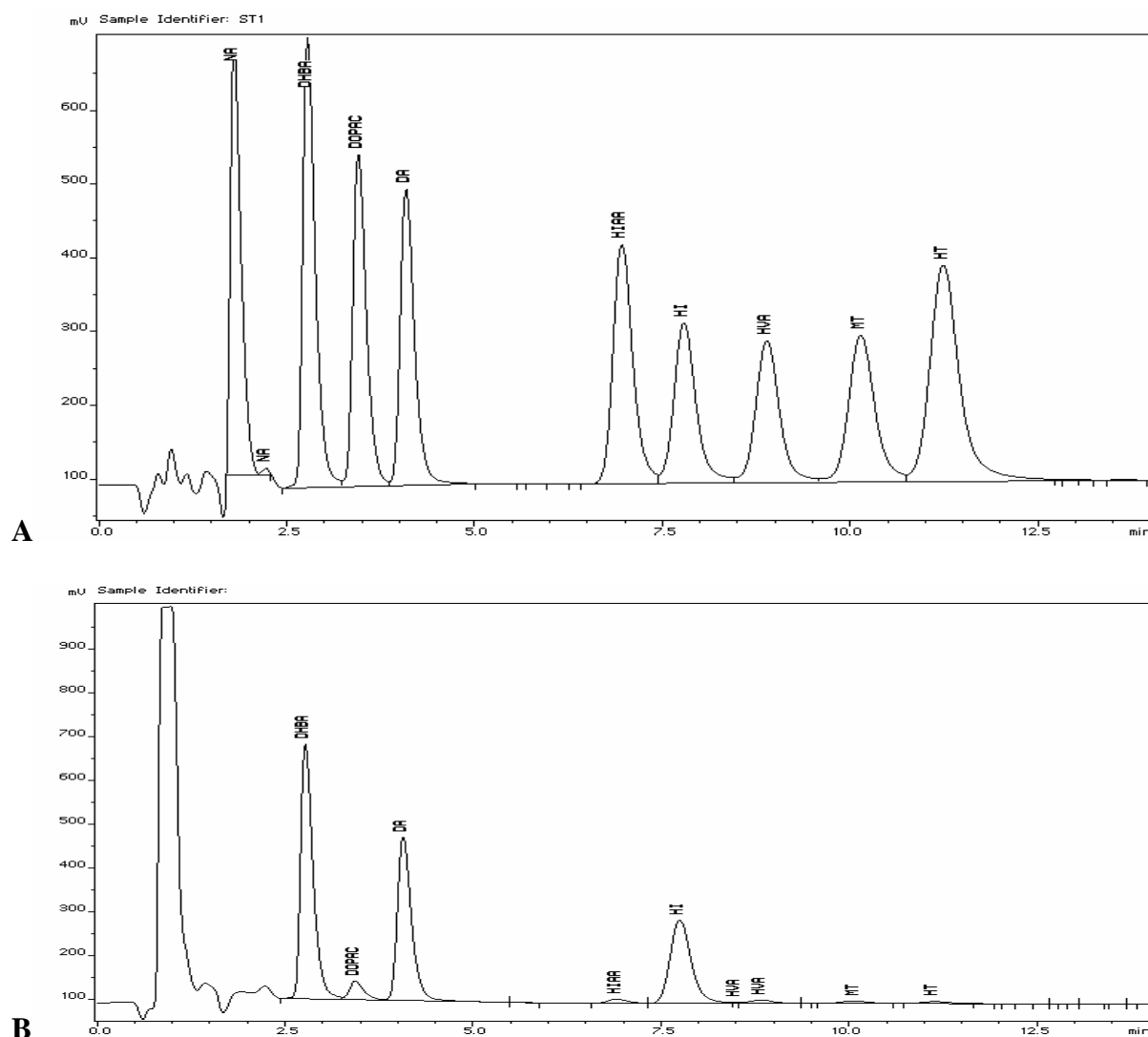

Fig.15 Representative of standard (A) and tissue (B) chromatograms.

Statistical Analyses and data presentation

In all the procedures, data were expressed as Means \pm SEM. Statistical analyses were carried out using, the GB-stat version 7 software (Dynamic Microsystem, Inc., 2000). Data for the behavioural studies were analysed using either non parametric or parametric statistics. One or two-way ANOVA was employed. Data were further submitted to post-hoc multi-comparison test. Microcal origin was used for graphical presentation of the data.

3. SUMMARY OF PUBLICATIONS

3.1 Manuscript I, Banjaw and Schmidt, 2004. Lyophilisation and freeze-precipitation as a method for crude extraction of cathinone from Catha edulis leaves with minimum thermal injury. Chemistry of Natural Compound 40: 611-12

The first question addressed at the outset of this study was how to maintain the active principle of the psychostimulant plant, *Catha edulis extract* since fresh leaves of the plant lose potency upon exposure to sunlight and easily degraded to a less potent compound known as, cathine (pseudo-ephedrine). To alleviate such rapid degradation of the active principle and minimize the thermal injury of *Catha edulis*, first the plant was transported from Addis Ababa to Germany under cold chains. Secondly, a lyophilisation and freeze-precipitation methods were designed to extract the active principle along with some other alkaloids. The methods yielded a lyophilised crude extract (0.35 % w/w). Quantitative or qualitative determination of cathinone in the lyophilised extract was made using spectrophotometer, thin layer chromatography (TLC) and high performance liquid chromatography (HPLC-UV/DAD). The result of these measurements showed that the presence of 5µg cathinone /mg lyophilised extract. The lyophilised extract prepared in such a way reconstituted well with saline and yielded a homogenous solution upon shaking. It was also easily administered via gavage to rats. Sunlight induced decomposition of cathinone during reconstitution and administration was minimized by wrapping the containers and the syringes with aluminium foils respectively.

3.2 Manuscript II, Banjaw and Schmidt, 2005. Behavioural sensitisation following repeated intermittent oral administration of Catha edulis in rats. Behav Brain Res 156: 181-189

Here is the question addressed whether or not a repeated oral administration of *Catha edulis* extract, cathinone or related congener, amphetamine induces alteration in the behaviour and level of neurotransmitters in the basal ganglia and limbic system. Locomotor activity,

stereotyped behaviour and the level of DA, 5-HT and their corresponding metabolites were used as indices to assess any alterations. The study explored also the stereotypy behaviour using sniffing paradigm. Two doses of *Catha edulis* extract (50 mg/kg or 200 mg/kg) were employed to assess the dose effect. For comparison purpose, S-(-)-cathinone (1.5 mg/kg, base) and d-(+)-amphetamine (1.5 mg/kg, base) were employed. Drugs were administered once daily for 9 consecutive days and later challenged with the same psychostimulants after five abstinence days. Then, two weeks later, rats were decapitated and the level of neurotransmitters were assessed. The results demonstrate that *Catha edulis* (200 mg/kg) induces a strong behavioural sensitisation and stereotypy in rats. Animals sensitised in this manner, however, did not show significant changes in the basal level of dopamine in most of the regions after two weeks of withdrawal except that *Catha edulis* extract (200 mg/kg) significantly reduced the level of DA, DOPAC and HVA in the anterior caudate putamen.

3.3 Manuscript III, Banjaw et al., 2005. Clozapine attenuates the locomotor sensitisation and the prepulse inhibition deficit induced by a repeated oral administration of Catha edulis extract and cathinone in rats. Behav Brain Res 160: 365-373

In an attempt to understand the effect of acute and repeated administration of *Catha edulis* extract or cathinone on locomotor sensitisation and deficits in prepulse inhibition (PPI), rats were given *Catha edulis* extract (200 mg/kg) or cathinone (1.5 mg/kg, base) every other days for a total of ten days. The rats were then challenged by administration of atypical antipsychotic drug, clozapine. The results of this study showed that repeated oral administration of cathinone or *Catha edulis* extract induced locomotor and exploratory activity similar to the previous studies (Banjaw and Schmidt, 2005) and additionally led to a gradual deficit in prepulse inhibition. Locomotor sensitisation and PPI deficit produced in this manner were slowly attenuated by a repeated administration of clozapine. Later, rats were challenged with the same psychostimulants, after two weeks of withdrawal from clozapine treatment i.e. day 40. The result of such latter investigations showed that the locomotor

responses of the rats were almost similar to the effect observed in the initial exposure (day 1) i.e., the rats did not show sensitized any profound locomotor activity. Assessment of the level of neurotransmitter in this study showed a significant DA increase in the prefrontal cortex. There was also a significant 5-HT decrease in the nucleus accumbens and its metabolite, 5-HIAA, in the prefrontal cortex. In the remaining regions, there were no significant changes. This was the first study to demonstrate that repeated administration of *Catha edulis extract*, or commercial cathinone, induces a prepulse inhibition deficit. And clozapine attenuated both *Catha edulis* or cathinone induced locomotor sensitisation and prepulse inhibition deficit.

3.4 Manuscript IV, Banjaw and Schmidt, 2005. Repeated Catha edulis oral administration enhances the baseline aggressive behaviour in isolated rats. Submitted to Journal of neural transmission

Though there are no substantial evidences or rigorous experimental studies, some traditionally or clinically observed evidences in the past indicate that repeated use of *Catha edulis* is commonly associated with an increased propensity for violent behaviour or aggression. Accordingly, the effects of repeated oral administration of the psychostimulant plant, *Catha edulis* (200 mg/kg) or its active principle, cathinone (1.5 mg/kg, base) was studied in rats using isolation induced aggression paradigm. The behavioural responses were videotaped and scored later by offline data analyses. The neurotransmitter correlates of each study was done at the end of the experiment by assessing the level of monoamines at a certain brain regions. The results revealed that repeated but not acute administration of *Catha edulis* extract or S(-)-cathinone enhanced significantly the locomotor activities (number of rearing and duration of ambulation) compared to the control. It enhanced also the baseline aggressive behaviours (upright offensive postures, biting-attack, chasing, kicking). The level of neurotransmitters showed a significant depletion of serotonin (5-HT) and its corresponding metabolites (5-HIAA) in both the anterior and posterior striatum. There was also a reduction in the level of homovanillic acid (HVA) in the hippocampus. The level of dopamine was also elevated in the

nucleus accumbens in those rats treated with *Catha edulis* extract. Cathinone, on the other hand, increased the level of HVA in the posterior striatum and decreased HVA in the nucleus accumbens. In conclusion, the present data demonstrate for the first time that repeated administration of *Catha edulis* or S-(-)-cathinone enhances aggression in rats, presumably by decreasing the level of 5-HT and its corresponding metabolites. Besides, the data obtained in this study did not rule out the involvement of dopamine in aggressive behaviour.

3.5 *Manuscript V, Banjaw et al., 2003. Anticataleptic activity of cathinone and MDMA (Ecstasy) upon acute and subchronic administration in rat. Synapse 49: 232-8*

This study shows that the psychostimulants, S-(-)-cathinone (1 mg/kg) or (RS)-MDMA (2.5 mg/kg) induce a strong anticataleptic activity upon acute subcutaneous administration to rats pre-treated with haloperidol (0.5 mg/kg, s.c.). The effect was later masked upon subchronic administration (days 2-7 & 26-29). On the contrary, when the same groups of rats were tested on day 8 in a different task, i.e. open-field, they showed a significant difference compared to control. The mechanism responsible for the strong anticataleptic activity of S-(-)-cathinone or MDMA requires further investigation.

4. GENERAL DISCUSSIONS

Lyophilisation and freeze-precipitation as a method for crude extraction of cathinone from *Catha edulis* leaves with minimum thermal injury: In the past, studies on *Catha edulis* illustrated the importance of using freshly harvested young shoots or leaves since the active principle, cathinone, readily degrades and produces another product known as cathine. This happens upon drying or storage of the cut plant material for a longer period (UN, 1977; Szendrei, 1980). Moreover, a study which involves crude extract requires normally identification and quantification procedures. Accordingly, here the content of *Catha edulis* Forsk (Celastraceae) leaves was extracted using lyophilisation and freeze precipitation methods. The extract was later standardised using appropriate techniques. The procedures yielded a lyophilised extract. The identification and quantification procedures of lyophilised extract were carried out using spectrophotometer, TLC and HPLC methods. The results obtained using such procedures were in line with previous reports (Szendrei, 1980; Al-Obaid, et al. 1998; Mathys and Brenneisen, 1992; Toennes and Kauert, 2002). The less thermal method comprising of organic solvent extraction followed by a freeze-precipitation and lyophilisation yielded a very good extract which was easily reconstituted and administered to rats (Manuscript –I, Banjaw and Schmidt, 2004, chemistry of natural compound, 40: 611-12).

Catha edulis, Cathinone or amphetamine induced behavioural sensitisation after intermittent oral administration: Animal studies have shown that repeated administration of amphetamine-like stimulants result in altered behavioural responses. One of the prominent feature of such alteration is behavioural sensitisation. Similarly, in this study, it was shown that acute and repeated intermittent oral administration of lyophilised *Catha edulis* extract induced the locomotor-activation. And ultimately leads to locomotor sensitisation and also stereotype behaviour in rats (Manuscript-II, Banjaw and Schmidt, 2005). The data indicate that *Catha edulis*, like amphetamine or cathinone, induces a strong alteration in behaviour. On the other hand, in unchallenged rats, 15 days after last drug administration, neurotransmitters

analyses showed absences of any significant alteration in the level of basal neurotransmitters in most of the regions except that *Catha edulis* extract (200 mg/kg) significantly reduced the level of DA, DOPAC and HVA in the anterior caudate putamen (Banjaw and Schmidt, 2005). Particularly, no alteration in the basal DA level of the nucleus accumbens was observed. The neurotransmitters-correlates for locomotor sensitisation induced by *Catha edulis* or cathinone, remains mysterious. On the other hand, the locomotor sensitisation was robust, even long lasting after five days of drug abstinence and re-exposure to the same psychostimulants. Our finding is in accordance with earlier reports on behavioural sensitisation which stated that a progressive augmentation of behavioural responses to psychomotor stimulants develops during repeated administration of psychostimulants and persists even after a long period of withdrawal (Stewart and Badiani, 1993; Pierce and Kalivas, 1997; Robinson and Becker, 1986; Kalivas et al., 1993; Segal and Kuczenski, 1994; Schmidt, 1998). This is the first result which show that repeated oral administration of *Catha edulis* or cathinone produces robust and augmented locomotor sensitisation, similar to the congener psychostimulant, amphetamine.

DA pathways extending from the brain stem to the limbic structures and cerebral cortex are generally considered to constitute the neuro-anatomical substrates underlying motivation, reward and motor function and also psychopathological conditions (Robinson and Becker, 1986). Some evidences have been also brought to support the involvement of pre-synaptic DA release after psychostimulant challenge as an important mechanism in the expression of behavioural sensitisation (Robinson and Becker, 1986). However, according to our findings, the basal DA level in the nucleus accumbens was not significantly changed after two weeks of withdrawal from the last challenge dose. The explanation for observed difference from previous reports is that there are several conflicting findings regarding neuronal sensitisation i.e., not all researchers have reported exactly the same profile regarding the level of neurotransmitters (Robinson and Becker, 1986). They reported either increase, decrease, or absence of nucleus accumbens DA depending upon the days of withdrawal, the study

protocols and animal strains (Robinson and Becker, 1986; Segal and Kuczenski, 1992a; 1992b; Kalivas and Duffy, 1993, Kalivas et al., 1993; Imperato et al., 1996; Heidbreder et al., 1996; Kuczenski et al., 1997; Koeltzow et al., 2003). For example, Heidbreder et al. (1996) demonstrated that cocaine pre-treated animals exhibited an enhanced motor response to a cocaine injection 2 days after cessation of cocaine treatment. The magnitude of this effect increased progressively over time. Basal DA overflow was elevated 2 days after termination of cocaine treatment; at this time, however, a blunted response of DA neurons to the cocaine administration was observed. As the duration of withdrawal increased, basal dialyzate DA concentrations gradually declined, whereas the response of DA neurons to cocaine progressively increased. Another study by Segal and Kuczenski (1992a), using in vivo microdialysis in freely-moving rats, demonstrated that repeated cocaine produced a behavioural sensitisation characterized by a downward oriented locomotor activation profile and both caudate and nucleus accumbens DA responses were significantly diminished in the drug pre-treated group. Their results, obtained following two days of drug withdrawal, differed from previous reports of an enhanced dopamine response after longer withdrawal intervals (Robinson and Becker, 1986). While the duration of withdrawal may play an important role in the quantitative features of the dopamine response to subsequent stimulant administration, their results suggest that an enhanced dopamine response may not be required for the expression of behavioural sensitisation. Finally, as it is summarised by Vanderschuren and Kalivas (2000), the distinctions between drugs in the induction and expression of sensitisation indicate that behavioural sensitisation can arise from multiple neuro-adaptations in multiple brain nuclei.

Psychostimulant induced psychosis and prepulse inhibition deficit: Prolonged administration of *Catha edulis* extract or cathinone to laboratory rats on everyday or every other day basis induced a long lasting locomotor sensitisation which persisted even after cessation of treatments (Manuscript-II, Banjaw and Schmidt, 2005; Manuscript-III, Banjaw et

al., 2005). Similarly, repeated administration of *Catha edulis* extract or cathinone to rats led to a prepulse inhibition deficit of the the startle reflex (Manuscript-III, Banjaw et al., 2005). Several studies indicate that stimulant-induced psychopathology, particularly in the form of paranoid psychosis, may often be associated with repeated exposure of psychostimulants (Robinson and Becker, 1986; Segal and Kuczenski, 1997). Moreover, locomotor sensitisation and prepulse inhibition deficit are typical paradigms that have been widely studied as animal behavioural models of psychosis and schizophrenia respectively. For example, in animal models, behavioural sensitisation to amphetamine-like psychostimulants is manifested as a progressive increase in drug-induced locomotion which may culminate in psychopathologies and considered to be the basis of psychosis (Robinson and Becker, 1986). It is also documented that prepulse inhibition deficit to a startle reflex is an animal model of schizophrenia which has long been associated with abnormalities in the information processing and attention mechanisms (Grillon et al., 1992; Braff, 1993; Swerdlow and Geyer, 1998). Psychosis and behavioural sensitisation in laboratory animals are frequently correlated (Robinson and Becker, 1986). Therefore, in our studies, the phenomenon of locomotor sensitisation and prepulse inhibition deficit induced by *Catha edulis* extract or cathinone, in laboratory animals may bear striking similarities to the progressive development of psychosis in human. For example, a clinical survey showed the association between repeated *Catha edulis* chewing and psychosis (Pantelis et al., 1989; Yousef et al., 1995; Alem and Shibre, 1997). Hence, the use of psychostimulants is often associated with a higher risk of psychosis (Farrell et al., 2002; Chen et al., 2003; Srisurapanont et al., 2003; Henquet et al., 2005). In conclusion, the capacity of *C. edulis* to elicit a long-lasting behavioural sensitisation support the anecdotal literatures about psychiatric problems associated with *C. edulis* chewing (Alem and Shibre, 1997; Awas et al., 1999).

Attenuation of locomotor sensitisation and prepulse inhibition deficit by atypical neuroleptic: *Catha edulis* extract or cathinone induced robust behavioural sensitisation and

prepulse inhibition deficit in laboratory rats (Manuscript-III, Banjaw et al., 2005). Such behavioural sensitisation and prepulse inhibition deficit were attenuated by repeated administration of clozapine. Combination of the drug and clozapine did lower the level of locomotion but did not completely block the expression of behavioural sensitisation. Whereas, repeated administration of clozapine alone for an additional four days (every other day) slowly attenuated the expression of behavioural sensitisation as demonstrated by a challenge dose after two weeks of withdrawal period. The mechanism underlining such an effect is still enigmatic. To explain the unique therapeutic effect of clozapine, many hypotheses have been proposed in the past. Most of the explanations assumed that clozapine action is associated with either dopamine receptor blockade or some other receptors (Brunello et al., 1995; Tauscher et al., 2004). Considering the dopaminergic receptor, it has been explained that the recently discovered D4 receptor subtype may play a crucial role in the action of clozapine and makes it more selective for such receptor subtype compared to D2 receptors and differs from all other conventional neuroleptics because of its mixed but weak D1/D2 antagonist characteristics (Brunello et al., 1995). This observation was based on the speculation that the synergism between D1 and D2 receptors might allow antipsychotic effects to be achieved below the threshold for unwanted motor side effects (Brunello et al., 1995). Serotonin receptors are also implicated for the clozapine activity (Meltzer, 1991; Meltzer et al., 2003). Another explanation for the clozapine action is that activity in neuronal populations in the frontal cortex is influenced by the basal ganglia and thalamus through basal ganglia–thalamocortical feedback pathways. Hence, manipulation of the glutamate receptors by clozapine (Arvanov and Wang, 1999; Goff and Coyle, 2001; Heresco-Levy, 2003; Pietraszek, 2003) might have also played a crucial role in attenuating the behavioural sensitisation and prepulse inhibition deficit. In fact, Dani and Zhoh (2004) outlined in their brief review that cortico-striatal glutamate afferents and mesostriatal DA afferents commonly converge onto the same postsynaptic spines of medium projection neurons. The consequent

synaptic triad provides an ideal configuration for dopamine modulation of glutamatergic transmission. Accordingly, PFC level DA could lead to a reduction in glutamate feedback (either by D2 inhibition of glutamatergic neuron or enhancement of GABAergic neurons possibly by D1 mechanism). More support to the notion of DA and glutamate interaction was further elucidated by Li et al. (2003) who showed that repeated intermittent treatment with amphetamine increases the density of dendritic spines on medium spiny neurons (MSNs) in the nucleus accumbens thereby facilitating neuronal plasticity (behavioural sensitisation). Accordingly, it could be explained that the behavioural sensitisation (in which glutamate-DA plays a crucial role) could presumably be attenuated upon repeated intermittent administration of antipsychotic agents, such as clozapine. Future investigations on the density of spiny neuron upon repeated exposure of antipsychotic agents would be beneficiary and may resolve the mechanism of repeated administration of clozapine. At this point, it would be mere speculation however to make any conclusive remarks on glutamate or GABA without measuring their actual level in the tissue.

Repeated administration of clozapine to *Catha edulis* pre-treated rats led to increase the level of DA in the prefrontal cortex (manuscript-III). It was speculated that the D1 antagonistic activity exerted by clozapine at low doses enhances preferentially the extracellular concentration of DA in specific areas of the brain, such as the prefrontal cortex, where a dopaminergic hypoactivity has been suggested to be in part responsible for negative symptoms of schizophrenia (Abi-Dargham and Moore, 2003). The clozapine enhancement of dopaminergic activity in this prefrontal cortex area might explain its efficacy against schizophrenia negative symptoms (Brunello et al., 1995; Meyer-Lindenberg et al., 1997; McGurk, 1999; Lindenmayer et al., 2004). It is also documented that the clinical onset of both the therapeutic and side effects of antipsychotic drugs can take days/weeks to develop

(Shilliam and Dawson, 2005). Therefore, it is likely that neuronal adaptive changes may only be manifested upon chronic administration of antipsychotics.

Aggression and repeated *Catha edulis* or cathinone administration: Our result showed for the first time that repeated but not acute oral administration of *Catha edulis* extract or cathinone enhanced the fighting behaviours (escalating type of attack-biting and kicking). By doing so, it alters the social interactions in isolated rats (manuscript- IV). Moreover, acute administration of *Catha edulis* extract or cathinone enhanced the locomotor and rearing activity but the locomotor activity was not different within the days indicating that increased fighting was not secondary to *Catha edulis* or cathinone-induced hyperactivity. Such effect was in accordance with previous report (Sokolov et al., 2004). The observed difference in aggressive behaviour during acute (no significant aggression) and chronic (escalated aggression) is also in agreement with a study using methamphetamine (METH) in mice (Sokolov et al., 2004). The aggressiveness due to chronic methamphetamine administration was tested in mice after chronic or long-term intermittent (8 weeks) or single exposures to the drugs. A single injection of METH (6 mg/kg) did not augment fighting. Whereas, chronic methamphetamine administration significantly increased the number of animals that initiated biting-attacks. Similarly, a study made using chronic methamphetamine abusers showed the presence of increased impulsivity, impairments in learning and attention (Richards et al., 1999). Moreover, in clinical studies, it was documented that there is a link between psychostimulants abuse and the number of criminal arrestees (Lipman, 2004). Such numbers have seriously impacted the criminal justice system from enforcement to the courts, corrections, and subsequent legal supervision agencies. Evidences like this one support the notion of linking aggression to chronic drug abuse. A study using alcohol also elucidated that its misuse can harm people other than the drinker, and can have negative consequences for society as a whole and commonly believed to play a role in decreased worker productivity,

increased unintentional injuries, aggression and violence against others, and child and spouse abuse (Gmel and Rehm, 2003).

The neuro-correlates with repeated *Catha edulis* extract or cathinone administration to the isolated rats revealed that there was a significant depletion of 5-HT and its corresponding metabolites (5-HIAA) in both the anterior and posterior striatum. There was also a reduction in the level of homovanillic acid (HVA) in the hippocampus. Additionally, elevation of DA level was observed in the Nacc, especially, in those rats treated with *Catha edulis* extract. Cathinone, on the other hand, increased the level of HVA in the posterior striatum and decreased HVA in the nucleus accumbens. Studies on aggression, so far, have attempted to identify the likely neurotransmitters and the particular brain regions associated with aggression. For example, inverse relationship between aggression and brain 5-HT or direct relationship between aggression and the level of DA was reported (Miczek and Fish, 2005). Hence the results we have obtained in our aggression study, low level of 5-HT and its corresponding metabolites, 5-hydroxyindoleacetic acid in isolated rats treated with *Catha edulis* or cathinone is in accordance with previous reports. In clinical study, 5-HT is decreased for example, following MDMA ("ecstasy") misuse (Curran et al., 2004). Such low 5-HT is associated with aggression and its users become more aggressive in the days following an acute dose of the drug. The involvement of 5-HT in the aggression behaviour further comes from another study which demonstrated that repeated cocaine (0.5 mg/kg) exposure throughout adolescence stimulates offensive aggression in hamsters (Ricci et al., 2004). The same study further showed that the cocaine-induced aggressive response was regulated by 5-HT(3) receptor activity. Implicating the role for 5-HT(3) receptors in adolescent cocaine-induced aggression.

Catalepsy and antiparkinsonian agents.

Acute subcutaneous administration of S-(-)-cathinone, like racemic MDMA strongly antagonized haloperidol-induced catalepsy (Manuscript V, Banjaw et al., 2003). The result

obtained from acute administration of cathinone or MDMA is in agreement with previous report from the same laboratory (Schmidt et al., 2002). This study was designed to investigate the beneficial effect of cathinone, the active principle of *Catha edulis* extract, at a dose comparable to that of human exposure. The data from the descent latency on bar and grid suggest that S-(-)-cathinone and racemic MDMA have a similar anticataleptic potency and more closely resemble in their anticataleptic action. However, the strong anticataleptic effect became weaker upon repeated administration of S-(-)-cathinone or racemic MDMA. This could probably be associated to behavioural sensitisation of catalepsy, i.e. the progressive augmentation of a response under repeated administration of a drug (Schmidt et al., 1999, Amtage and Schmidt, 2003). The results from the present study document that upon further investigations, S-(-)-cathinone could be considered as one of potential candidates in the search for a new drug for the treatment of Parkinson's disease with minimal dyskinesia inducing potential or it could as well be an important additions to the Parkinson's disease treatment armamentarium.

5. CONCLUSIONS AND RECOMMENDATIONS

Conclusions: Acute and daily subchronic administration of lyophilised *Catha edulis* extract showed a robust behavioural sensitisation which was similar to the effect produced by pure cathinone or amphetamine. The behavioural sensitisation elicited with *Catha edulis* extract was long lasting and persisted after cessation of drug treatment. The capacity of *Catha edulis* extract to elicit long-lasting behavioural sensitisation in rats supports the anecdotal literatures about psychiatric problems associated with *Catha edulis* chewing since behavioural sensitisation in rodents by amphetamine is considered to be an animal model of amphetamine psychosis. Acute oral administration of cathinone or *Catha edulis* extract produced also an enhanced locomotor activity but no PPI deficit. Whereas, repeated administration of *Catha edulis* extract every other day induced both the development of behavioural sensitisation and PPI deficit. These alterations in the behaviour are related to psychopathological conditions, i.e. psychosis and schizophrenia. The development of behavioural sensitisation and PPI deficit were attenuated upon repeated administration of clozapine. Re-drug testing after two-weeks of abstinence did not cause expression of behavioural sensitisation. There was a significant increase in the level of DA in the prefrontal cortex and a significant decrease in the level of 5-HT in the nucleus accumbens and 5-HIAA in the prefrontal cortex.

Our aggression study in isolated rats shows for the first time that repeated administration of *Catha edulis* or S-(-)-cathinone enhances exploratory and ambulatory. It also demonstrates the enhancement of baseline composite aggressions (biting-attack, chasing, the tendency to use the hind paws to kick at the body of the intruder and offensive upright postures). In addition, increases ano-genital sniffing and mounting behaviours. There was also depletion of 5-HT and 5-HIAA in both the anterior and posterior striatum. Reduction in the level HVA was also observed in the hippocampus. Finally, the results from catalepsy study documented that acute

administration of S-(-)-cathinone reverses catalepsy induced by haloperidol. The anticataleptic effect of cathinone, however, was later masked upon repeated testing.

Recommendations: Finally, much remains to be done on the long effect of *Catha edulis* extract, especially the emotional aspects: impairment of judgments or learning and memory, anxiety and impulsivity. Such studies could contribute further information to the causes of household violence, gambling, lethargy for work and traffic related accidents in Ethiopia. Further studies should as well be conducted on the neuro-toxicity of *Catha edulis* extract using immunohistochemistry, attenuation of aggression behaviours, the role of *Catha edulis* in the early gene expressions, such as cJun and cFos and treatment of *Catha edulis* abusers. Last but not least, further study is also recommended on the antiparkinsonian activity of *Catha edulis* extract.

6. REFERENCES

- Abi-Dargham A, Moore H (2003) Prefrontal DA transmission at D1 receptors and the pathology of schizophrenia. *Neuroscientist*. 9: 404-16
- Agid Y, Javoy F, Glowinski J (1974) Chemical or electrolytic lesion of the substantia nigra: early effects on neostriatal dopamine metabolism. *Brain Res*. 74: 41-9
- Alam M, Schmidt WJ (2000) Rotenone destroys dopaminergic neurons and induces parkinsonian symptoms in rats. *Behav Brain Res*. 136: 317-24
- Alem A, Shibre T (1997) Khat induced Psychosis and its medico-legal implication: a case report. *Ethiop Med J* 35: 137-9
- Al-Meshal IA, Qureshi S, Ageel AM, Tariq M (1991) The toxicity of *Catha edulis* (khat) in mice. *J Subst Abuse*. 3(1): 107-15
- Al-Motarreb A, Baker K, Bradley KJ (2002) Khat: pharmacological and medical aspects and its social use in Yemen. *Phytother Res* 16: 403-13
- Al-Obaid AM, Al-Tamrah SA, Aly FA, Alwarthan AA (1998) Determination of S(-) Cathinone by spectrophotometric detection. *J.Pharm.Biomed.Anal* 17: 321-326
- Amtage J, Schmidt WJ (2003) Context-dependent catalepsy intensification is due to classical conditioning and sensitisation. *Behav Pharmacol*. 14: 563-7
- Ananth J, Burgoyne KS, Gadasalli R, Aquino S (2001) How do the atypical antipsychotics work? *J Psychiatry Neurosci*. 26: 385-94
- Andersen MP, Pouzet B (2001) Effects of acute versus chronic treatment with typical or atypical antipsychotics on d-amphetamine-induced sensorimotor gating deficits in rats. *Psychopharmacology (Berl)*, 156: 291-304
- Andrews N, File SE (1993) Increased 5-HT release mediates the anxiogenic response during benzodiazepine withdrawal: a review of supporting neurochemical and behavioural evidence. *Psychopharmacology (Berl)* 112: 21-5
- Arvanov VL, Wang RY (1999) Clozapine, but not haloperidol, prevents the functional hyperactivity of N-methyl-D-aspartate receptors in rat cortical neurons induced by subchronic administration of phencyclidine. *J Pharmacol Exp Ther*. 289: 1000-6
- Ayana AM, Sherief HT, Tekli Y (2002) Effect of khat (*Catha edulis* Forsk) on blood pressure and heart rate, a community based study. *Ethiop J HealthDev*. 16: 325-334
- Awais M, Kebede D, Alem A (1999) Major mental disorders in Butajira, southern Ethiopia. *Acta Psychiatr Scand Suppl*. 397: 56-64.
- Balint GA, Ghebregidhan H, Balint EE (1991) *Catha edulis*, an international socio-medical problem with considerable pharmacological implications. *East Afr Med J*. 68: 555-61
- Banjaw MY, Schmidt WJ (2005) Behavioral sensitization following repeated intermittent oral administration of *Catha edulis* in rats. *Behav Brain Res*, 156: 181-189
- Barnes NM, Sharp T (1999) A review of central 5-HT receptors and their function. *Neuropharmacology* 38: 1083-152
- Baumgarten HG, Grozdanovic Z (1995) Psychopharmacology of central serotonergic systems. *Pharmacopsychiatry Suppl* 2: 73-9
- BBC News (2002) BBC new Africa, Ethiopian Khat Dilemma.
- Bell RL, Rodd ZA, Hsu CC, Lumeng L, Murphy JM, McBride WJ (2003) Amphetamine-modified acoustic startle responding and prepulse inhibition in adult and adolescent alcohol-preferring and -nonpreferring rats. *Pharmacol Biochem Behav* 75: 163-171
- Betarbet R, Sherer TB, Di Monte DA, Greenamyre JT (2002) Mechanistic approaches to Parkinson's disease pathogenesis. *Brain Pathol*. 12: 499-510
- Birdsall TC (1998) 5-Hydroxytryptophan: a clinically-effective serotonin precursor. *Altern Med Rev*. 3: 271-80
- Braff DL (1993) Information processing and attention dysfunctions in schizophrenia. *Schizophr Bull*. 19: 233-59

- Braff DL, Geyer MA, Swerdlow NR (2001) Human studies of prepulse inhibition of startle: normal subjects, patient groups, and pharmacological studies. *Psychopharmacology*, 156: 234-58
- Brenneisen R, Fisch HU, Koelbing U, Geisslülser S, Kalix P (1990) Amphetamine-like effects in humans of the Khat alkaloid Cathinone. *British Journal of Clinical Pharmacology* 30: 825-828.
- Brunello N, Masotto C, Steardo L, Markstein R, Racagni G (1995) New insights into the biology of schizophrenia through the mechanism of action of clozapine. *Neuropsychopharmacology*.13: 177-213
- Caine SB, Negus SS, Mello NK, Patel S, Bristow L, Kulagowski J, Vallone D, Saiardi A, Borrelli E (2002) Role of dopamine D2-like receptors in cocaine self-administration: studies with D2 receptor mutant mice and novel D2 receptor antagonists. *J Neurosci*. 22: 2977-88
- Carlsson A (1959) The occurrence, distribution and physiological role of catecholamines in the nervous system. *Pharmacol. Rev.* 11: 490-493
- Chen CK, Lin SK, Sham PC, Ball D, Loh EW, Hsiao CC, Chiang YL, Ree SC, Lee CH, Murray RM (2003) Pre-morbid characteristics and co-morbidity of methamphetamine users with and without psychosis. *Psychol Med.* 33: 1407-14
- Cho AK, Segal DS (1994) *Amphetamine and its analogs* 1st ed Academic Press. Inc. San Diego, California. pp 1- 10
- Cooper JR, Bloom FE, Roth RH (1996) Dopamine In: *The Biochemical Basis of Neuropharmacology*. New York: Oxford University Press;: 293-351
- Cowen PJ (1991) Serotonin receptor subtypes: implications for psychopharmacology. *Br J Psychiatry Suppl.* 12: 7-14
- Curran HV, Rees H, Hoare T, Hoshi R, Bond A (2004) Empathy and aggression: two faces of ecstasy? A study of interpretative cognitive bias and mood change in ecstasy users. *Psychopharmacology (Berl)*.173: 425-33
- Damier P, Hirsch EC, Agid Y, Graybiel AM (1999) The substantia nigra of the human brain. II. Patterns of loss of dopamine-containing neurons in Parkinson's disease. *Brain*.122: 1437-1448
- Dani JA, Zhou FM (2004) Selective dopamine filter of glutamate striatal afferents *Neuron*. 42(4):522-4
- Deakin JF (1998) The role of serotonin in panic, anxiety and depression. *Int Clin Psychopharmacol. Suppl* 4: 51-5
- Dechass, L (2001) *Khat (Catha edulis): Botany, Distribution, Cultivation, Usage and Economics in Ethiopia*. United Nations Development Programme UNDP – Emergencies Unit for Ethiopia(EUE)
- Dhaifalah I, Santavy J (2004). Khat habit and its health effect. *A natural amphetamine. Biomed Pap* 148(1):11-5.
- Dziedzicka-Wasylewska M (2004) Brain dopamine receptors - research perspectives and potential sites of regulation. *Pol J Pharmacol*.56: 659-71
- Eison AS, Eison MS (1994) Serotonergic mechanisms in anxiety. *Prog Neuropsychopharmacol Biol Psychiatry* 18: 47-62
- Elmi AS, Ahmed YH, Samatar MS (1987) Experience in the control of khat-chewing in Somalia. *Bull Narc.* 39(2): 51-7
- Farrell M, Boys A, Bebbington P, Brugha T, Coid J, Jenkins R, Lewis G, Meltzer H, Marsden J, Singleton N, Taylor C (2002) Psychosis and drug dependence: results from a national survey of prisoners. *Br J Psychiatry*.181:393-8
- Feldon J, Weiner I (1992) From an animal model of an attentional deficit towards new insights into the pathophysiology of schizophrenia. *J Psychiatr Res.* 26: 345-66
- Fendt M, Li L and Yeomans JS (2001) Brain stem circuits mediating prepulse inhibition of the startle reflex. *Psychopharmacology* 156: 216-224

- Fleckenstein AE, Haughey HM Metzger RR, Kokoshka JM, Riddle EL, Hanson JE; Gibb, JW and Hanson GR (1999) Differential effects of psychostimulants and related agents on dopaminergic and serotonergic transporter function. *Eur J Pharmacol* 382: 45-9
- Geyer MA, Krebs-Thomson K, Braff DL, Swerdlow NR (2001) Pharmacological studies of prepulse inhibition models of sensorimotor gating deficits in schizophrenia: a decade in review *Psychopharmacology*, 156: 117–154
- Giannini AJ, Castellani S (1982) A manic-like psychosis due to khat (*Catha edulis* Forsk.). *J Toxicol Clin Toxicol.*19: 455-9
- Glennon RA, Liebowitz SM (1982) Serotonin Receptor Affinity of Cathinone and Related Analogues. *J.Med.Chem.* 25: 393-397
- Gmel G, Rehm J (2003) Harmful alcohol use. *Alcohol Res Health.* 27: 52-62
- Goff DC, Coyle JT (2001)The emerging role of glutamate in the pathophysiology and treatment of schizophrenia. *Am J Psychiatry.* 158: 1367-77
- Goldstein M, Ceasar P, Anagnoste B (1976) Lesions of the nigro-striatal dopamine pathway: effects on the storage and metabolism of striatal dopamine. *Pharmacol Ther* 2: 89-95
- Gosnell BA, Yracheta JM, Bell SM, Lane KE (1996) Intravenous self administration of cathinone by rats. *Behavioral. Pharmacology* 6: 526 –531
- Grillon C, Ameli R, Charney DS, Krystal J, Braff D (1992) Startle gating deficits occur across prepulse intensities in schizophrenic patients. *Biol Psychiatry.* 32: 939-43
- Heffner TG, Hartman JA and Seiden LS (1980) A rapid method for the regional dissection of the rat brain. *Pharmacol Biochem Behav* 13: 453-456
- Heidbreder CA, Thompson AC, Shippenberg TS (1996) Role of extracellular dopamine in the initiation and long-term expression of behavioral sensitization to cocaine. *J Pharmacol Exp Ther.* 278: 490-502
- Henquet C, Krabbendam L, Spauwen J, Kaplan C, Lieb R, Wittchen HU, van Os J (2005) Prospective cohort study of cannabis use, predisposition for psychosis, and psychotic symptoms in young people. *BMJ* 330: 11
- Heresco-Levy U (2003) Glutamatergic neurotransmission modulation and the mechanisms of antipsychotic atypicality. *Prog Neuropsychopharmacol Biol Psychiatry.* 27: 1113-23
- Hill BG (1965) Cat (*Catha edulis* Forsk) *Journal of Ethiopian studies* 3: 13-23
- Hokfelt T, Fuxe K, Goldstein M (1975) Applications of immunohistochemistry to studies on monoamine cell systems with special reference to nervous tissues. *Ann N Y Acad Sci.* 254: 407-32
- Honkanen A (1999) Modulation of brain dopaminergic neurotransmission in alcohol-preferring rats by alcohol and opioids. Ph.D thesis. Faculty of Science of the University of Helsinki, Helsinki Finland.
- Hoyer D, Clarke DE, Fozard JR, Hartig PR, Martin GR, Mylecharane EJ, Saxena PR, Humphrey PP (1994) International Union of Pharmacology classification of receptors for 5-hydroxytryptamine (Serotonin) *Pharmacol Rev.* 46: 157-203
- Hurtig HI (1997) Problems with current pharmacological treatment of Parkinson's disease. *Exp Neurol* 144:10–16
- Imperato A, Obinu MC, Carta G, Mascia MS, Casu MA, Gessa GL (1996) Reduction of dopamine release and synthesis by repeated amphetamine treatment: role in behavioural sensitisation. *Eur J Pharmacol*, 317: 231-7
- Kalix P (1982) The amphetamine-like releasing effect of the alkaloid (-)-cathinone on rat nucleus accumbens and rabbit caudate nucleus. *Prog Neuropsychopharmacol Biol Psychiatry.* 6: 43-9
- Kalix P (1991) The pharmacology of psychoactive alkaloids from Ephedra and Catha. *J. Ethnopharmacology* 32: 201-208
- Kalix P, Branden O (1985). Pharmacological aspects of the chewing of khat leaves. *Pharmacol. Rev.* 37: 149-164

- Kandel ER, Schwartz JH, Jessell TM (2000) Principle of neuronal science, 4th ed McGraw-Hill/Appleton & Lange Companies, Inc.
- Kalivas PW, Duffy P (1993) Time course of extracellular dopamine and behavioural sensitisation to cocaine. I. Dopamine axon terminals. *J Neurosci*, 13: 266-75
- Kalivas PW, Sorg BA, Hooks MS (1993) The pharmacology and neural circuitry of sensitisation to psychostimulants. *Behav Pharmacol*, 4: 315-334.
- Kapur S, Seeman P (2001) Does fast dissociation from the dopamine d(2) receptor explain the action of atypical antipsychotics?: A new hypothesis. *Am J Psychiatry*.158: 360-9
- Kapur S, Zipursky RB, Remington G (1999) Clinical and theoretical implications of 5-HT₂ and D₂ receptor occupancy of clozapine, risperidone, and olanzapine in schizophrenia. *Am J Psychiatry*. 156: 286-93
- Kebede Y (2002) Cigarette smoking and khat chewing among university instructors in Ethiopia. *East Afr Med J* 79: 274-8
- Kelley AE (2004) Memory and addiction: shared neural circuitry and molecular mechanisms. *Neuron* 44: 161-79
- Kelley AE, Andrzejewski ME, Baldwin AE, Hernandez PJ, Pratt WE (2003) Glutamate-mediated plasticity in corticostriatal networks: role in adaptive motor learning. *Ann N Y Acad Sci*.1003:159-68
- Koch M (1999) The neurobiology of startle. *Prog Neurobiol*. 59: 107-28
- Koch M, Fendt M (2003) Startle response modulation as a behavioural tool in neuropharmacology. *Curr. Neuropharmacol* 1: 175-185
- Koeltzow TE, Austin JD and Vezina P (2003) Behavioural sensitisation to quinpirole is not associated with increased nucleus accumbens dopamine overflow. *Neuropharmacology*, 44: 102-10.
- Kuczenski R, Segal DS, Todd PK (1997) Behavioural Sensitisation and extracellular dopamine responses to amphetamine after various treatments. *Psychopharmacology (Berl)*134: 221-229
- Kumari V, Soni W and Sharma T (1999) Normalization of information processing deficits in schizophrenia with clozapine. *Am J Psychiatry*, 156: 1046-51
- Lebsanft HB, Kohles T, Kovar KA, Schmidt WJ (2005) 3,4-Methylenedioxymethamphetamine counteracts akinesia enantioselectively in rat rotational behavior and catalepsy. *Synapse*. 55: 148-55
- Leng A, Feldon J, Ferger B (2004) Long-term social isolation and medial prefrontal cortex: dopaminergic and cholinergic neurotransmission. *Pharmacol Biochem Behav* 77:371-9
- Li Y, Kolb B, Robinson T (2003) The location of persistent amphetamine-induced in the density of dendritic spines on medium spiny neurons in the nucleus accumbens and caudate putamen. *Neuropsychopharmacology* 28(6): 1082-5
- Lindenmayer JP, Czobor P, Volavka J, Lieberman JA, Citrome L, Sheitman B, McEvoy JP, Cooper TB, Chakos M (2004) Effects of atypical antipsychotics on the syndromal profile in treatment-resistant schizophrenia. *J Clin Psychiatry*. 65: 551-6
- Lipman JJ (2004) Psychometric Profiles of Violent Offenders with Histories of Psychostimulant Psychosis: A Pilot study *Int J forensic psychology* 1: 82-93
- Lipska BK (2004) Using animal models to test a neuro-developmental hypothesis of schizophrenia. *J Psychiatry Neurosci*. 29: 282-6
- Mansbach RS, Geyer MA, Braff DL (1988) Dopaminergic stimulation disrupts sensorimotor gating in the rat *Psychopharmacology*, 2: 299-308
- Mathys K, Brenneisen R (1992) Determination of (S)-(-)-cathinone and its metabolites (R,S)-(-)-norephedrine and (R,R)-(-)-norpseudoephedrine in urine by high-performance liquid chromatography with photodiode-array detection. *J Chromatogr* 593: 79-85
- Matsumoto K, Cai B, Satoh T, Ohta H, Watanabe H (1991) Desipramine enhances isolation-induced aggressive behavior in mice. *Pharmacol Biochem Behav*. 39:167-70

- McGurk SR (1999) The effects of clozapine on cognitive functioning in schizophrenia. *J Clin Psychiatry*. 60 Suppl 12: 24-9
- Meltzer HY (1991) The mechanism of action of novel antipsychotic drugs. *Schizophr Bull*. 17: 263-87
- Meltzer HY, Li Z, Kaneda Y, Ichikawa J (2003) Serotonin receptors: their key role in drugs to treat schizophrenia. *Prog Neuropsychopharmacol Biol Psychiatry*. 27: 1159-72
- Mereu GP, Pacitti C, Argiolas A (1983) Effect of (-)-cathinone, a khat leaf constituent, on dopaminergic firing and dopamine metabolism in the rat brain. *Life Sci*. 32:1383-9
- Meyer-Lindenberg A, Gruppe H, Bauer U, Lis S, Krieger S, Gallhofer B (1997) Improvement of cognitive function in schizophrenic patients receiving clozapine or zotepine: results from a double-blind study. *Pharmacopsychiatry*. 30: 35-42
- Miachon S, Rochet T, Mathian B, Barbagli B, Claustrat B (1993) Long-term isolation of Wistar rats alters brain monoamine turnover, blood corticosterone, and ACTH. *Brain Res Bull*. 32: 611-4.
- Miczek KA, Fish EW (2005) Dopamine, Glutamate and aggression in Dopamine and Glutamate in Psychiatric Disorders, Schmidt, Werner, J. (University of Tuebingen, Tuebingen, Germany) and Reith, Maarten, E. A.(New York University School of Medicine, New York, NY), Humana Press Scientific and Medical publisher, TOTOWA, New Jersey. Book in press.
- Miczek KA, Fish EW, De Bold JF, De Almeida RM (2002) Social and neural determinants of aggressive behavior: pharmacotherapeutic targets at serotonin, dopamine and gamma-aminobutyric acid systems. *Psychopharmacology (Berl)*. 163: 434-58
- Miczek KA, O'Donnell JM (1978) Intruder-evoked aggression in isolated and non isolated mice: effects of psychomotor stimulants and L-dopa *Psychopharmacology (Berl)* 57: 47-55
- Nencini P, Grassi MC, Botan AA, Asseyr AF, Paroli E (1989) Khat chewing spread to the Somali community in Rome. *Drug Alcohol Depend*. 23: 255-8
- Nielsen JA (1985) Cathinone affects dopamine and 5-hydroxytryptamine neurons in vivo as measured by changes in metabolites and synthesis in four forebrain regions in the rat. *Neuropharmacology*. 24: 845-52
- Oak JN, Oldenhof J, Van Tol HH (2000) The dopamine D(4) receptor: one decade of research. *Eur J Pharmacol*. 405(1-3):303-27
- Pantelis C, Hindler CG, Taylor JC (1989) Use and abuse of khat (*Catha edulis*): a review of the distribution, pharmacology, side effects and a description of psychosis attributed to khat chewing. *Psychol Med*.19(3):657-68
- Parent A, Côté P, Lavoie B (1995) Chemical Anatomy of primate basal ganglia. *Prog Neurobiol* 46: 131-197
- Parent A, Hazrati L (1995) Functional anatomy of the basal ganglia: The place of subthalamic nucleus and external pallidum in basal ganglia circuitry. *Brain.Res Rev* 20: 128-154
- Pehk EA, Schechter MD, Yamamoto BK(1990) Effects of cathinone and amphetamine on the neurochemistry of dopamine in vivo. *Neuropharmacology*. 29:1171-6
- Pierce RC and Kalivas PW (1997) A circuitry model of the expression of behavioural sensitisation to amphetamine-like psychostimulants. *Brain Res Brain Res Rev*. 25: 192-216.
- Pietraszek M (2003) Significance of dysfunctional glutamatergic transmission for the development of psychotic symptoms. *Pol J Pharmacol*. 55: 133-54
- Pifl C, Drobny H, Reither H, Hornykiewicz O, Singer EA (1995) Mechanism of the dopamine-releasing actions of amphetamine and cocaine: plasmalemmal dopamine transporter versus vesicular monoamine transporter. *Mol Pharmacol*. 47: 368-73
- Rech RH, Moore KE (1971) An introduction to psychopharmacology 1st ed. Raven press. New York. North-Holland publishing company Amsterdam. 138-154

- Remington G (2003) Understanding antipsychotic "atypicality": a clinical and pharmacological moving target. *J Psychiatry Neurosci.* 28: 275-84
- Richards JB, Sabol KE, de Wit H (1999) Effects of methamphetamine on the adjusting amount procedure, a model of impulsive behavior in rats. *Psychopharmacology.* 146: 432-9
- Rilke O, Freier D, Jahkel M, Oehler J (1998) Dynamic alterations of serotonergic metabolism and receptors during social isolation of low- and high-active mice. *Pharmacol Biochem Behav* 59: 891-6
- Ricci LA, Grimes JM, Melloni RH (2004) Serotonin type 3 receptors modulate the aggression-stimulating effects of adolescent cocaine exposure in Syrian hamsters (*Mesocricetus auratus*). *Behav Neurosci.* 118: 1097-110
- Robinson TE and Becker JB (1986) Enduring changes in brain and behaviour produced by chronic amphetamine administration : A review and Evaluation of animal models of Amphetamine Psychosis. *Brain Res.* 11: 157-198
- Rothman RB, Vu N, Partilla JS, Roth BL, Hufeisen SJ, Compton-Toth BA, Birkes J, Young R and Glennon RA (2003) In vitro characterization of ephedrine-related stereoisomers at biogenic amine transporters and the receptorome reveals selective actions as norepinephrine transporter substrates. *J Pharmacol Exp Ther,* ; 307:138-45
- Saxena PR (1995) Serotonin receptors: subtypes, functional responses and therapeutic relevance. *Pharmacol Ther.* 66: 339-68
- Schechter MD (1990) Dopaminergic nature of acute cathine tolerance. *Pharmacol Biochem Behav,* 1990; 36: 817-20
- Schmidt WJ, Kretschmer BD (1997) Behavioural pharmacology of glutamate receptors in the basal ganglia. *Neurosci Biobehav Rev.* 21: 381-92
- Schmidt WJ (1995) Balance of transmitter activities in the basal ganglia loops. *J Neural Transm Suppl.* 46:67-76
- Schmidt WJ (1998) Basal ganglia dopamine and glutamate in motor activation and plasticity. *Neur Psychiatry brain res.* 6:155-160
- Schmidt WJ, Kretschmer BD (1997) Behavioural pharmacology of glutamate receptors in the basal ganglia. *Neurosci biobehav rev.* 21: 381-392
- Schmidt WJ, Mayerhofer A, Meyer A, Kovar KA (2002) Ecstasy counteracts catalepsy in rats, an anti-parkinsonian effect? *Neurosci Lett.* 330: 251-4
- Schmidt WJ, Tzschentke TM, Kretschmer BD (1999) State-dependent blockade of haloperidol-induced sensitization of catalepsy by MK-801. *Eur J Neurosci.* 11: 3365-8
- Scholey AB, Parrott AC, Buchanan T, Heffernan TM, Ling J, Rodgers J (2004) Increased intensity of Ecstasy and polydrug usage in the more experienced recreational Ecstasy/MDMA users: a WWW study. *Addict Behav.* 29: 743-52
- Schreiber R, De Vry J (1993) 5-HT_{1A} receptor ligands in animal models of anxiety, impulsivity and depression: multiple mechanisms of action? *Prog Neuropsychopharmacol Biol Psychiatry.* 17: 87-104
- Segal DS, Kuczenski R (1992a) Repeated cocaine administration induces behavioural sensitisation and corresponding decreased extracellular dopamine responses in caudate and accumbens. *Brain Res.* 577: 351-5
- Segal DS, Kuczenski R (1992b) In vivo microdialysis reveals a diminished amphetamine-induced DA response to behavioural produced by repeated amphetamine pretreatment. *Brain Res,* 571: 330-7
- Segal DS, Kuczenski R (1994) Behavioral pharmacology of amphetamine. In: *Amphetamine and its analogs* (Cho AK, Segal DS, eds), pp 115–150. San Diego: Academic.
- Segal DS, Kuczenski R (1997) An Escalating Dose "Binge" Model of Amphetamine Psychosis: Behavioral and Neurochemical Characteristics. *J. Neurosci.* 17 2551–2566
- Selassie SG and Gebre A (1996) Rapid assessment of drug abuse in Ethiopia. *Bull Narc.* 48: 53-63.

- Self DW(2004) Regulation of drug-taking and -seeking behaviors by neuroadaptations in the mesolimbic dopamine system. *Neuropharmacology*. Suppl 1: 242-55
- Shadan P, Shellard, E J (1962) An anatomical study of Ethiopian khat (leaf of *Catha edulis* Forsk) *Journal of pharmacy and pharmacology*, 14:110-118
- Shearer J, Gowing LR (2004) Pharmacotherapies for problematic psychostimulant use: a review of current research. *Drug Alcohol Rev*. 23: 203-11
- Shilliam CS, Dawson LA (2005) The Effect of Clozapine on Extracellular Dopamine Levels in the Shell Subregion of the Rat Nucleus Accumbens is Reversed Following Chronic Administration: Comparison with a Selective 5-HT(2C) Receptor Antagonist. *Neuropsychopharmacology*. 30: 372-80
- Siegel A, Roeling TA, Gregg TR, Kruk MR (1999) Neuropharmacology of brain-stimulation-evoked aggression. *Neurosci Biobehav*. 23:359-89
- Simantov R (2004) Multiple molecular and neuropharmacological effects of MDMA (Ecstasy) *Life Sci*. 74: 803-14
- Snyder SH, Taylor KM, Coyle JT, Meyerhoff JL (1970) The role of brain dopamine in behavioral regulation and the actions of psychotropic drugs. *Am J Psychiatry*.127: 199-207
- Sokolov BP, Schindler CW, Cadet JL (2004) Chronic methamphetamine increases fighting in mice. *Pharmacol Biochem Behav*. 77 :319-26.
- Sparago M, Wlos J, Yuan J, Hatzidimitriou G, Tolliver J, Cason TD, Katz J, Ricaurte G (1996) Neurotoxic and Pharmacologic Studies on Enantiomers of the N-Methylated Analog of Cathione (Methcathinone): A New Drug abuse. *Pharm. Exp.Ther*. 279: 1043 –1052
- Srisurapanont M, Ali R, Marsden J, Sunga A, Wada K, Monteiro M (2003)Psychotic symptoms in methamphetamine psychotic in-patients. *Int J Neuropsychopharmacol*. 6:347-52
- Stewart J, Badiani A (1993)Tolerance and sensitisation to the behavioural effects of drugs. *Behav Pharmacol*. 4: 289-312.
- Swerdlow NR, Braff DL, Taaid N, Geyer MA (1994) Assessing the validity of an animal model of deficient sensorimotor gating in schizophrenic patients. *Arch Gen Psychiatry* 51: 139-54
- Swerdlow NR, Geyer MA (1998) Using an animal model of deficient sensorimotor gating to study the pathophysiology and new treatments of schizophrenia. *Schizophr Bull*. 24: 285-301
- Swerdlow NR, Geyer MA (1993) Clozapine and haloperidol in an animal model of sensorimotor gating deficits in schizophrenia. *Pharmacol Biochem Behav*. 44: 741-4
- Swerdlow NR, Geyer MA (1998) Using an animal model of deficient sensorimotor gating to study the pathophysiology and new treatments of schizophrenia. *Schizophr Bull*. 24: 285-301
- Szendrei K(1980) Extraction, screening investigations and solvent ... central stimulant activity of cathinone obtained from *Catha edulis*", UN.ODCCP Bulletin on Narcotics.
- Takakusaki K, Saitoh K, Harada H, Kashiwayanagi M.(2004) Role of basal ganglia-brainstem pathways in the control of motor behaviors. *Neurosci Res*. 50: 137-51
- Tauscher J, Hussain T, Agid O, Verhoeff NP, Wilson AA, Houle S, Remington G, Zipursky RB, Kapur S (2004) Equivalent occupancy of dopamine D1 and D2 receptors with clozapine: differentiation from other atypical antipsychotics. *Am J Psychiatry*.161: 1620-5
- Toennes SW, Kauert GF (2002) Excretion and detection of cathione , cathine and phenylpropanolamine in urine after Kath Chewing *Clin.Chem* 48: 1715-1719

- Toennes SW, Harder S, Schramm M, Niess C and Kauert GF (2003) Pharmacokinetics of cathinone, cathine and norephedrine after the chewing of khat leaves. *Br J Clin Pharmacol.* 56: 125-30.
- UN (1956) United Nations Office on drugs and crime 1956/01/01.
- UN (1977) United Nations Office on drugs and crime. Substances isolated from khat (UNwebsite) (MNAR/7/1977)
- UN (1975) United Nations Office on drugs and crime. Studies on the chemical composition of Khat. Investigations on the phenylalkylamine fraction (MNAR/11/75)
- Vanderschuren LJ, Kalivas PW (2000) Alterations in dopaminergic and glutamatergic transmission in the induction and expression of behavioral sensitization: a critical review of preclinical studies. *Psychopharmacology (Berl).* 151: 99-120
- Van Zwieten-Boot BJ, Noach EL (1975) The effect of blocking dopamine release on synthesis rate of dopamine in the striatum of the rat. *Eur J Pharmacol.* 33: 247-54
- Voigtlander PF, Moore KE (1971) Nigro-striatal pathway: stimulation-evoked release of (3 H)dopamine from caudate nucleus. *Brain Res.* 35: 580-3
- Widler P, Mathys KJ, Brenneisen R, Kalix P, Fisch Hu (1994) Pharmacodynamics and pharmacokinetics of Khat a controll study. *Clin Pharmacol Ther* 55: 556-62
- Yamamoto J (2004) Recent trends of drug abuse in Japan. *Ann N Y Acad Sci.* 1025:430-8
- Yousef G, Huq Z, Lambert T (1995) Khat chewing as a cause of psychosis (pubmed Abstract). *Br J Hosp Med.* 54: 322-6
- Zein ZA (1988) Polydrug abuse among Ethiopian university students with particular reference to khat (*Catha edulis*). *J Trop Med Hyg.* 91: 71-5
- Zelger JL, Schorno HX, Carkini EA (1980) Behavioural effects of Cathinone, an amine obtained from *Catha edulis* Forsk: Comparisons with amphetamine, norpseudephedrine, apomorphine and nomifensine. *Bull Narc,* 32: 67-81

"To the man who pleases him, God gives wisdom, knowledge and happiness..... „ Ecclesiastes 2:26

There are different choices in life but wisdom determines one's destination. How nice it is to pursue unswervingly a choice which leads to education (without rebellion), love (without hypocrisy), inner peace (without pretension) and forgiveness (without grudge).

This piece of work is dedicated to my beloved wife for waiting patiently and devoting her entire energy while taking care of our two lovely children (Bersabeh & Menase) until this journey is over.

May my late brother's soul rest in peace.

Acknowledgments

Could simple thanks or handclaps or applause with "daumen druecken" express my sincere gratitude to my supervisor, Professor Werner J. Schmidt? Not in any way. He deserves more words of honour for sharing his valuable research experience and guidance in those three years. Even when he was at a climax of intra and extra-curricular activities, he was there for me to listen my research progress and comment on it. His fruitful discussions and unlimited advice shaped me in many ways. He encouraged me to express my feeling without any fear in all those three years and made me self confident. He went beyond his own boundary to train an African young generation in a newly emerging subject, neuropharmacology. By doing so, he made an impact at a remote area while being in Germany. What else could I say? Thank you very much for what you have done. It means a lot to have someone like you to count on.

I owe my sincere gratitude to my co-authors, PD Dr. Markus Fendt, Department of Animal Physiology, Dr. Andreas Mayerhofer, Department of Neuropharmacology, University of Tuebingen and Professor Dr. Klaus Miczek, Department of Psychology, Pscychiatry, and Neuroscience, Tufts University, USA for helping me to widen my research horizon.

My wife, I run short of words to express my thanks. You were patient in all those three years. You acted as Daddy and Mammy for our lovely children. You were available for them at the time of need. You took care of them in my absence. May the Almighty God Bless you now and forever more.

My special thank goes to KAAD for the financial support I have been receiving for the last three years.

Last but not least, my heartfelt salute and thanks also go to colleagues in our Department of Neuropharmacology and my friends in all over Germany for helping me achieve this goal. God bless you all.

Curriculum Vitae

Name: Mehret Yerdaw Banjaw
Date of birth: 10-09-67
Place of birth: Shoa, Ethiopia
Marital status: Married with two children

Academic credentials:

2002 – 2005: Dissertation, Department of Neuropharmacology, Zoological Institute
Faculty of Biology, Eberhard Karls University, Tuebingen, under the
supervision of Professor Werner J. Schmidt

1997- 2001 Addis Ababa University, School of Pharmacy (Teaching Assistant)

1994- 1996 Norwegian University of Science and Technology (NTNU), Cand. Scient.

1989- 1993 Addis Ababa University, School of Pharmacy (Teaching Assistant)

1983- 1988 B.Pharm, Addis Ababa University, School of Pharmacy

1979- 1982 High School, Shashemene, Shoa, Ethiopia